

BERNHARDT | design

shift
price list

september 2011

terms and conditions	3 - 4
design selection	5 - 7
product details	8 - 13
electrical management	14
workwalls	15
guaranteed freight	16
desk tops	18
desk modesty panels	19
desk pedestals	20 - 21
accent credenzas	22
credenza tops	23
bridge tops	26
return tops	27 - 28
corner tops	29
asymmetrical tops	30

peninsula pedestals	32
pedestals	33
open pedestals - laterals	34
laterals	35 - 36
back panels	37 - 38
support panels	39
overhead support panel	40-42
accent overheads	43
worksurface towers	44 - 49
tackboards	50 - 51
vertical storage	52 - 57
freestanding files/bookcases	58
electrical components	59 - 60
accessories	61 - 64
hardware	65

Prices and Terms

Prices and specifications are subject to change without notice. All prices quoted will be FOB our factories. Terms are net 30 days. A service charge of 1½% per month will be charged on all past due accounts.

Order Entry

All orders are subject to final acceptance by Bernhardt Design in Lenoir, NC. Receipt of our acknowledgment indicates acceptance of your order subject to the terms set forth on the acknowledgment.

Bernhardt Design attempts to clarify all purchase orders. However, in the event the price list number and description on the purchase order differ, the price list number will prevail.

Change Orders

All reasonable requests for changes to standard orders will be honored if received in writing prior to the start of production. Custom design and special finish orders are not subject to revision after acknowledgment. Bernhardt Design reserves the right to charge for labor, materials and administration costs for all order changes.

Cancellations

All acknowledged orders are considered as firm orders and are not subject to cancellation.

Custom Design

Bernhardt Design may alter products to meet specific needs. Contact your local sales representative when a custom design is needed. Custom designs require minimum quantities, additional lead time and upcharges. A custom job number, available from your local sales representative, must be submitted with purchase orders. Orders combining custom design with standard product cannot be scheduled for production until custom items are approved.

COM for Tackboards

All COM for tackboards should be shipped to the following address and tagged as follows:

Bernhardt Design
Plant 7T Door #10
1402 Morganton Blvd
Lenoir, NC 28645
Dealer: _____
Tag For: _____
Product No: _____
PO No: _____
Acknowledgment No: _____

All tackboard COM will be cut and applied at the discretion of Bernhardt Design unless special cutting instructions identifying and stating horizontal or vertical application are included in writing with the purchase order. Bernhardt Design will not be held responsible for defective fabrics as all COM's are accepted as first quality goods.

Shipping

Bernhardt Design will ship in accordance with customer instructions whenever possible. If not specified, Bernhardt Design will exercise its best judgement in selecting a carrier. Orders in production will be shipped as scheduled and cannot be held.

High quality cartoning which meets trucking and railroad specifications is standard at no extra charge. Some items may be blanket wrapped for shipment.

Storage

If a customer is unable to accept an order when it is ready for shipment, storage may be requested. Acceptance of storage will be at the discretion of Bernhardt Design. All costs including transportation will be at customer expense. A storage charge of 1½% of the invoice will be assessed for every 30 days, or any part thereof, that merchandise remains in storage. Bernhardt Design considers transfer to storage the equivalent of delivery.

This includes invoicing and payment. Customers will bear all risk of damage or loss during storage.

Freight Damage and Claims

Bernhardt Design is not liable for damages that occur during transit or storage. The carrier assumes all responsibility upon acceptance of product. It is the customer's responsibility to inspect all products upon receipt and file any claims with the carrier. No product should be refused. If products are received damaged, a written exception should be made on the bill of lading and an immediate inspection be requested of the carrier. Concealed damage must be reported to the carrier within 15 days of receipt. Failure to make claims shall constitute acceptance of the products and waiver any claims of defects, errors or shortages.

In the event delivery is made on a Bernhardt Design truck, the products should be carefully inspected for transit damage. If contents are damaged, the driver should be notified to call his dispatcher for immediate disposition. Concealed damage must be reported within 15 days of receipt and product/packaging held for inspection by a Bernhardt Design representative.

Replacements for product damaged in shipment or storage will be manufactured upon receipt of a purchase order.

Returns

No merchandise may be returned to Bernhardt Design without written consent in the form of a Return Authorization from our Quality Assurance Department, stating why the item is being returned and how the item will be shipped. In the event a return is authorized by Bernhardt Design for reasons other than damage or defect, the customer shall be responsible for a

25% restocking fee, as well as a double freight charge.

Unauthorized returns will be automatically refused by our receiving department as well as returns not in accordance with Bernhardt Design shipping instructions. Liability for defective merchandise shall be limited to the replacement or repair of that merchandise, and Bernhardt Design shall not be liable for other damages or losses.

Measurements and Weights

All measurements and weights are approximate and subject to change without notice.

Care and Cleaning

Finished wood surfaces should be cleaned with a soft damp cloth, wiping in the direction of the grain. Furniture should be buffed dry immediately with a soft cloth.

Wood Finishes

Bernhardt Design casegoods are available in finishes that are compatible with tables and seating finishes. However, finishes on casegoods may vary slightly from those on tables and seating due to the natural characteristics of the wood. No absolute match is implied or guaranteed.

Light Finishes

Bernhardt Design offers lighter finishes 836, 837, 840 and 850 on certain veneers. Light finishes do not hide or mask the natural characteristics of the wood. Therefore, inherent natural characteristics of the wood will vary from piece to piece when using a light finish. Natural characteristics include the natural discolorations of the wood substance and color variations in glued up stock.

These natural characteristics are not considered defects by Bernhardt Design, and therefore merchandise will not be replaced.

Special Finishes

Special finishes, made to customer specifications and subject to factory approval, may be available at a **5% net upcharge with a \$500 net minimum**. Additional leadtime may be required for special finish items. Special finish orders will not be acknowledged until the special finish sample is approved in writing and received by Bernhardt Design Customer Service. Special finish orders are not subject to revision or cancellation after acknowledgment.

Installation and Maintenance

All freestanding casegoods are equipped with leveling devices. Local floor conditions vary, and it is always necessary to properly adjust leveling devices. Proper leveling is essential to the alignment and function of doors and drawers. Improperly leveled units result in misaligned doors and drawers and may impair locking mechanisms or other functional hardware.

After the initial installation of casegoods, it may be necessary to re-adjust and align the units to compensate for settling. This should be expected as a matter of routine maintenance and follow-up to assure proper case function.

Proper installation of Bernhardt Design casegoods is the responsibility of the dealer. Improperly installed units can result in permanent damage to case components. Damage due to improperly installed furniture is not covered under product warranty.

Warranty

Bernhardt Design will repair or replace, at its discretion, any casegoods product or part thereof which fails as the result of defects in material and workmanship, under single shift use and normal care for five years. This warranty shall apply only to the original purchaser.

This warranty does not cover normal wear and tear, misuse or abuse of product, dramatic temperature changes, exposure to unusual conditions or damages incurred by contact with seating products, tables, desks or other surfaces.

Natural color changes, variations or movements in lumber or veneer products, exposure to extreme temperature changes and direct sunlight may cause color changes and/or surface damage. These are circumstances beyond the control of Bernhardt Design and are not warranty issues.

Repair or replacement of discontinued product will be at the discretion of Bernhardt Design. This warranty is the customer's exclusive remedy for product defect and does not apply to damage caused by a freight carrier, dealer, installer, user modification, attachments to a product, or any third party. Bernhardt Design has the exclusive right to make the final determination of product misuse or abuse.

Except as stated above, Bernhardt Design makes no express or implied warranties as to any product, and in particular, makes no warranty of merchantability or of fitness for any particular purpose. Bernhardt Design shall not be liable for any consequential or incidental damages or for commercial loss arising from any product defect.

Operational Parts Warranty

Drawer glides, drawer boxes, drawer pulls, and lock mechanisms have a Life-Time Warranty for original purchaser. Power/communications components are warranted for one year.

Wall Mount Units Warranty

Wall mounted units are supplied with an adequate attachment

device but not with hardware to attach this device to the support wall. It is the responsibility of the dealer/installer to ensure the wall structure is adequate to support the unit and that the attachment device is properly secured to the wall structure.

Design and Patent Rights

All of the products shown in Bernhardt Design catalogs and described in Bernhardt Design price lists are, and remain, the property of Bernhardt Design, with the sole right reserved to manufacture and to distribute.

Some of the product designs shown are patented in the United States and will remain the property of Bernhardt Design. Any reproduction of the products constitutes an infringement of patented copyright laws and will be subject to prosecution.

Bernhardt Design reserves the right to make changes in dimensions, design and/or construction, price lists, or product literature without prior notice.

General Services Administration

All Shift products are available on the Bernhardt Design GSA - Federal Supply Service Contract GS-28F-7040G.

For information regarding GSA pricing, please contact your local Bernhardt Design Sales Representative or call 828 759 6337.

Send all GSA payments to:
12197 Collections Center Drive
Chicago IL 60693

Environmental Certification

LEVEL 1 CERTIFIED: All casegoods within the Shift collection meet the multi-attribute sustainable standards for BIFMA Level 1 Certification. For more information along with proof of certification and a complete listing of certified products visit levelcertified.org.

GREENGUARD CERTIFIED: The Shift collection is GREENGUARD certified and certificates are available on Bernhardttdesign.com or GREENGUARD.org.

FSC CERTIFICATION: Bernhardt Design also offers FSC chain-of-custody certification for Shift casegoods. For more information on FSC availability and pricing, please contact bgreen@bernhardtdesign.com.

Shift Ordering Information

Each item has a multi character ordering code comprised of letters and numbers representing design selections found in the specification code grid. The grid is located at the bottom of each page and lists the selections particular to the items shown on that page. The grid immediately below shows all design selections possible for Shift casegoods. Explanations of each design selection follows.

specification codes	series	sku	veneer	style	pull/hardware	finish	grommet placement
reference page XX for product details	<input type="checkbox"/> W wood veneer <input type="checkbox"/> P paint <input type="checkbox"/> C accessories <input type="checkbox"/> K components		grade 1 <input type="checkbox"/> X paint <input type="checkbox"/> J cherry <input type="checkbox"/> 9 walnut <input type="checkbox"/> E maple grade 2 <input type="checkbox"/> Q anigre	<input type="checkbox"/> F flat edge <input type="checkbox"/> M metal edge <input type="checkbox"/> S shaped edge <input type="checkbox"/> X none	<input type="checkbox"/> 2 self pull <input type="checkbox"/> 4 aluminum <input type="checkbox"/> 7 aluminum tab <input type="checkbox"/> 9 ecru leather <input type="checkbox"/> X none	see page 7	<input type="checkbox"/> 1 3" left <input type="checkbox"/> 5 9" left <input type="checkbox"/> 2 3" right <input type="checkbox"/> 6 9" right <input type="checkbox"/> 3 3" both <input type="checkbox"/> 7 9" both <input type="checkbox"/> 4 3" center <input type="checkbox"/> 8 9" center <input type="checkbox"/> X none 3" grommet/\$65each 9" grommet specify separately see page 61

Series Selections

W Wood Veneer
Four species of veneer with standard finishes are offered on worksurface tops, cases and components in the Shift collection. Special finishes are available subject to upcharges. Worksurface tops are only available in the wood veneer option.

P Paint
Six paint finishes are available as standard in the Shift collection. Custom colors are available subject to upcharges. The paint option is available on cases and components where noted as an option in the series specification codes.

C Accessories
Bernhardt Design offers a variety of accessories including task lighting, electrical management, desk and drawer accessories.

Sku Selections

Sku/Product Number
A three character sku identifies each product. Information including dimensions, weight and pricing is provided for each sku. General information for product groupings start on page 8.

Veneer - Grade 1

X Paint
Cases: Paint
Tops: Not Available

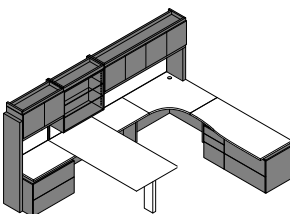

J Cherry
Solids: Cherry
Cases: Quarter Cut

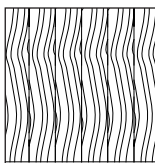

Tops: Flat Cut

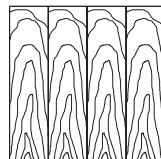

9 Walnut
Solids: Walnut
Cases: Quarter Cut

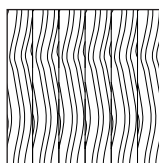

Tops: Flat Cut

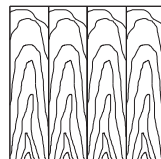

E Maple
Solids: Maple
Cases: Quarter Cut

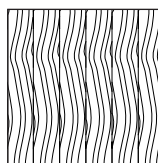

Tops: Flat Cut

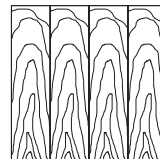

Veneer - Grade 2

Q Anigre
Solids: Maple
Cases: Quarter Cut

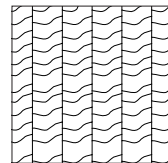

Tops: Quarter Cut

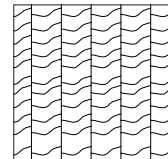

Style Selections

F Flat Edge - Wood



M Metal Edge - Aluminum



S Shaped Edge - Wood



Pull/Hardware Selections

2 Self Pull

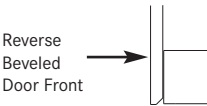

Overhead door fronts have the option of a reverse bevel door pull design when the self pull is specified.

4 Anodized Aluminum

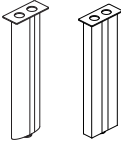

Peninsula Legs

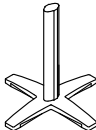

S Series Base



Communication Grommet

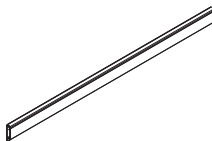

Accessory Rail

7 Aluminum Tab



Drawer Pull



Door Pull

9 Ecrú Leather



Drawer Pull



Door Pull

Glass door units utilize the aluminum tab pulls only.

Finish Selections

□□□ Finish Number

A three character sku identifies the finish selection available on each species. Individual components are priced with standard finish. Special finishes made to customer specifications are subject to factory approval and a 5% net upcharge with a \$500 net minimum.

Transparent stains and sealers are applied in multiple steps to enhance the beauty of the natural wood. A durable, baked-on, top-coat of conversion varnish or UV topcoat is applied to protect the product. It is recommended that felt, cork or fabric backed desk pads and accessories are used on worksurfaces to minimize wear.

When specifying light finishes such as 836, 837, 840 or 850, the color and characteristic variances of both veneer and solid wood are apparent. Therefore, exact color matches are not possible.

Paint	Cherry	Walnut	Maple	Anigre
Standard Finish	Standard Finish	Standard Finish	Standard Finish	Standard Finish
101	805	823	837	805
102	834	839	850	823
103	835	841		834
104	836	860		836
105	839	861		839
106	840			840
	841			841
	861			850
				860
				861

Grommet Placement Selections

Grommets are available in worksurfaces for wire management. Specified as left, right, both left and right, or center, the exact placement of the grommet must be specified on the purchase order and cannot be changed or added after an order is acknowledged and entered into production.

For desks specify the 3" round brushed aluminum grommet. The 3" grommets are \$50 list each. The 9" communication grommet must be used in an open kneewell for maximum effectiveness. The 9" communication grommet must be ordered separately. See page 59 for the available skus for the 9" communication grommets. See page 14 for additional communication grommet information.

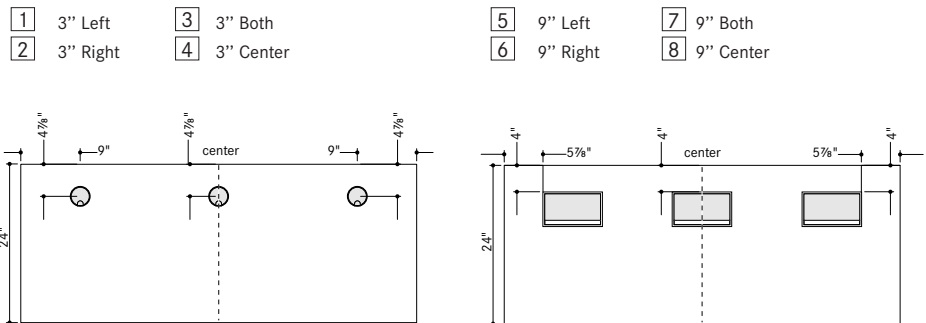

Desks

A Shift desk is specified by components. A top, a modesty panel and two pedestals are specified separately for a desk. Assembly required. All skus include hardware.

To order a desk:

1. Specify sku for the appropriate desk top size.
2. Determine style of modesty panel. Specify modesty panel for the appropriate style of panel – flush or recessed – and for the corresponding desk top size.
3. Specify pedestal for user left installation based on modesty panel selection.
4. Specify pedestal for user right installation based on modesty panel selection.

Components for Pedestal Desk with Flush Modesty Panel

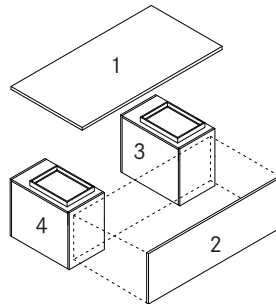

Components for Pedestal Desk with Recessed Modesty Panel

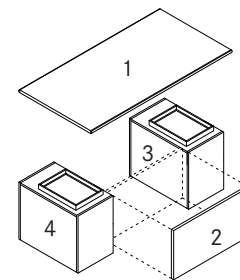

Desk Tops

Available in a variety of sizes with a flat wood edge or an aluminum edge on four sides or a shaped wood edge on user and guest sides only. See page 6 for edge profile options. Desk tops overhang 5" on the guest side. Brushed aluminum 3" grommets are available for wire management with desk tops. Specify grommet placement when ordering top. Grommets are \$50 list each. Available in wood veneer only. The paint finish option is not available on desk tops.

Desk Tops for Flush or Recessed Modesty Panels

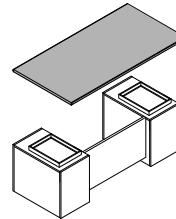
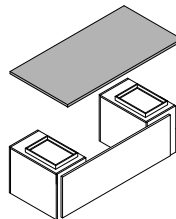

Modesty Panels

Two options are available. The flush front modesty panel aligns vertically with the spacers of the pedestals. The recessed modesty panel is inset 4" back from the face of the pedestals. The bottom of both the flush and the recessed modesty panels stops 3" above the floor. The width of the modesty panel is determined by the size of the top. Available in a wood veneer or paint finish.

Flush Modesty Panel

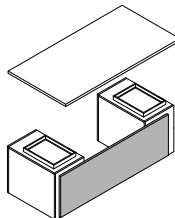

Recessed Modesty Panel

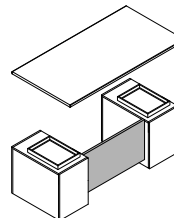

Desk Pedestals

All desk pedestals have a 2" h aluminum spacer supporting the desk top. Two pedestals must be specified for a desk. Options include box/box/file (BBF), file/file (FF) and shelf pedestals. See pages 20 and 21 for pedestal options. For flush modesty panel application, specify pedestals designed for a flush panel. BBF and FF pedestals for flush panels may be used for right or left installation. For recessed modesty panel application, specify pedestals designed for a recessed modesty panel. BBF and FF pedestals for recessed panels must be specified for user right or left installation. Shelf pedestals must be ordered for right or left application for both flush and recessed modesty panels. Shelf pedestals are used in L or U configurations. Drawers have pulls, gang locks and file bars. Pedestals have adjustable levelers and plastic floor glides. Available in a wood veneer or paint finish.

Pedestals for Flush or Recessed Modesty Panels

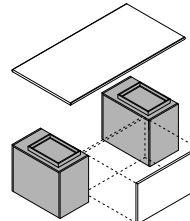
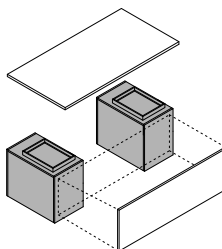

Right Shelf Pedestal in U Configuration

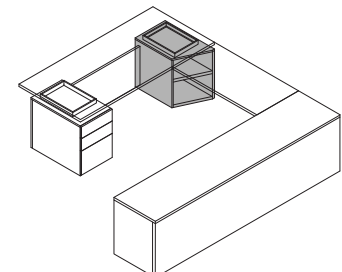

Pedestals/Laterals

Designed to use with a variety of worksurface tops to create credenzas, returns and workcenter units. Pedestals/laterals have an aluminum spacer that supports the top. Options include door, drawer and open shelf configurations. Door units have pulls, gang locks and shelves. Drawer units have pulls, gang locks and file bars with standard black back. File bars and rails are included and can accommodate letter, legal, A-4 and foolscap filing.

Mobile pedestals/laterals can be freestanding or placed under standard worksurfaces. A BF mobile pedestal is available with a seat cushion or finished top. Fabric must be specified for the seat cushion option. See page 3 for instructions on tagging COM fabrics. A mobile lateral has a box drawer with open shelves below with a finished back and top.

Specialty laterals include a freestanding anti-tilt FF and a refrigerator lateral that provides a space for a compact, maximum 1.5 cubic feet refrigerator. Refrigerator must be purchased separately. The interior of the refrigerator lateral is equipped with ventilation holes and measures 20" w x 22" d x 23" h. A 6" minimum clearance must be maintained from the back of the refrigerator and the back panel. Available in paint finish or wood veneer. Specialty laterals have finished backs.

All pedestals/laterals have adjustable levelers and plastic floor glides. Available in a wood veneer or paint finish.

Pedestals: 15 7/8" wide

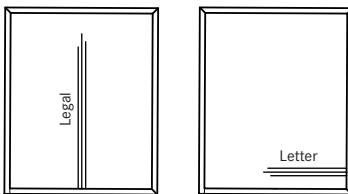

18 7/8" Depth

Pedestals: 18" wide

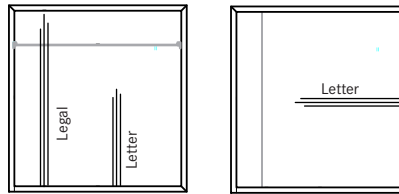

18" Depth

Laterals: 30" wide

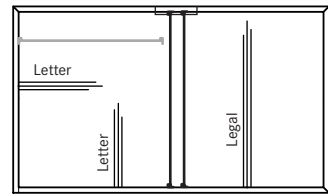

Center rails must not be removed.

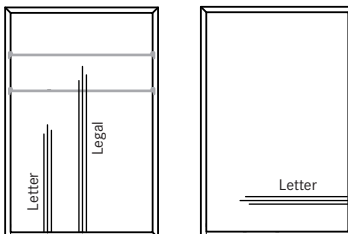

23 7/8" Depth

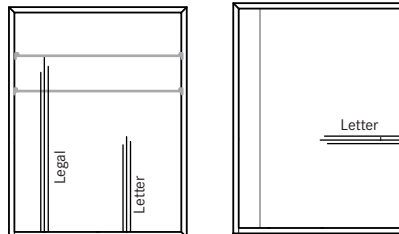

23 7/8" Depth

Laterals: 36" wide

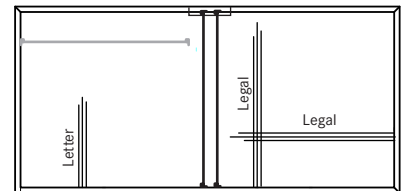

Center rails must not be removed.

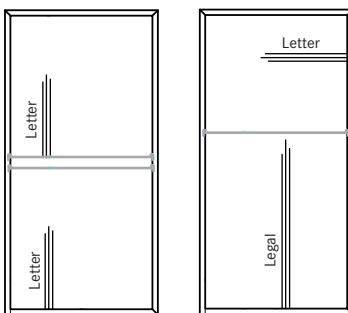

28 7/8" Depth

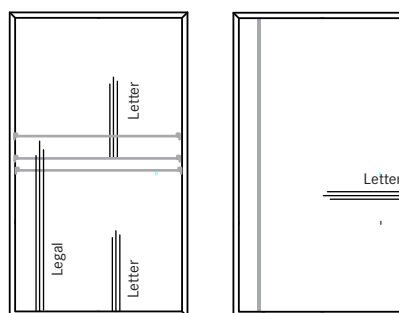

28 7/8" Depth

Back Panels

Designed for a variety of needs. A fixed panel closes the back of a credenza/workwall and is finished on both sides. The access back panel closes the back of the credenza/work-wall but allows access to electrical and communication sources. The panel can be used with the power harness, standard grommet or the communication grommet. The panel can be lifted 1/4" and removed for access to wall. Finished on the inside only.

The fabric access panel is grey, nylon mesh material attached to aluminum support extrusions that completely removes with a hook-on application. Fabric panels collapse to the floor for easy, clear access to outlets and wires.

All panels include necessary hardware for connection to tops and adjacent panels.

Wood Access Back Panel



Fabric Access Back Panel

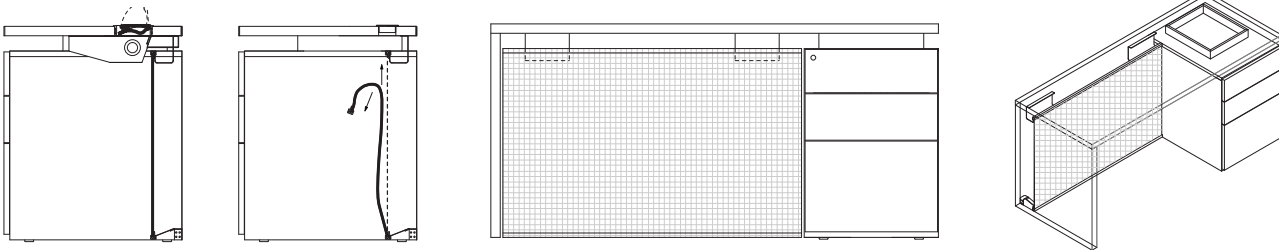

Support Panels

End panels support the void end of a credenza with the opposite end supported by a pedestal/lateral. A bridge back panel is used with a bridge top in U configurations. The end support panel is used with a pedestal leg support and a pedestal top.

Mid-support panels are used in long runs of credenza tops used to form T configurations. A mid-support must be used on spans longer than 48".

A corner support chasis supports a corner top and connects with returns, credenzas and bridge worksurfaces to create workcenters. The corner support is not to be used in a freestanding application. Wire access provided. Assembly required.

All support panels include necessary hardware for connection to top and/or adjacent panels. Levelers included. Available in paint finish or wood veneer.

End Panel

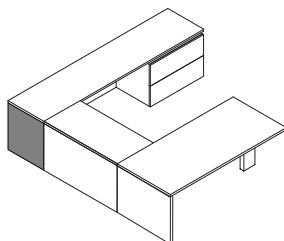

Bridge Back Panel

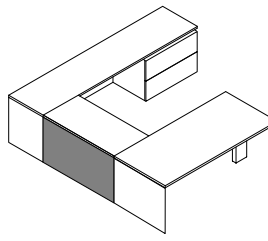

End Support Panel

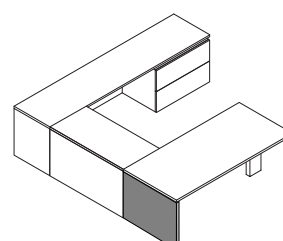

Mid-Support Panel

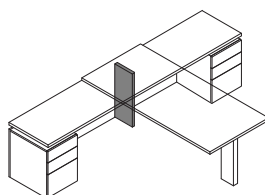

Corner Support Panel

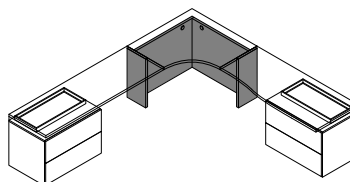

A mid-support must be used on spans longer than 48"

Overhead Panels

Panels for overheads include panels that stack on worksurfaces or attach to base units. A 24" h panel is designed for use on a worksurface. Right or left application must be specified for the 24" panel. Taller panels – 68¾" h for single binder height; 78" h for double – attach to the overhead. A mid-support panel is recommended for use when specifying overheads 108" w x 33½" h. Panels may be used in combination with worksurface towers or vertical storage units.

An open organizer with three adjustable wood shelves is also available for use on a worksurface in a stacking application. Available in four widths.

All overhead panels are available in wood veneer or paint finish. Installation hardware included.

Overhead End Panel

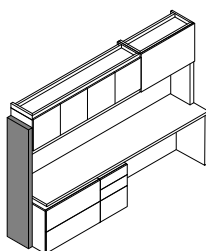

Overhead Worksurface Panel - Left

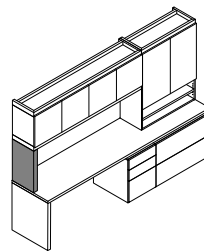

Overhead Worksurface Panel - Right

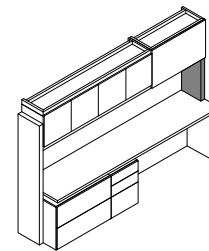

Overhead Worksurface Mid-Support Panel

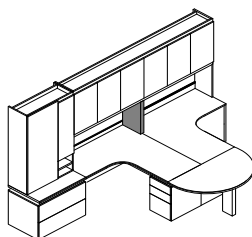

Overhead Worksurface Organizer

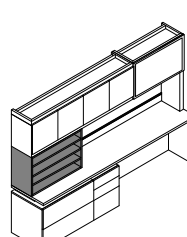

Overheads

Available in single and double binder height for wall mounting to structurally reinforced walls; stacking on top of worksurfaces using open low organizers or support panels; freestanding with use of the overhead support panel attached to base units; or installed with worksurface towers or vertical storage units. Options include open overheads and overheads with doors. Doors are standard sizes with concealed three-way adjustable hinges with an automatic closing feature. When there are three doors, the odd door will be located on the right side and will open to the right. Pull/hardware or the self pull, touch latch system utilizing a reverse beveled edge band on the bottom of the overhead may be specified. Overhead units can accommodate locks as a custom and will require an upcharge. Overheads are designed to conceal task lighting; however, task lighting must be specified separately. The upper rail can conceal ambient light fixtures up to 2 1/2" h. Available in a wood veneer or a paint finish.

Accent overheads include glass door and shelf units. Glass door units feature back-painted white, starfire glass with aluminum trim and an aluminum tab pull. An open wall mount bookcase with glass shelves is designed for use with an aluminum trimmed filler panel in wood or glass that must be specified separately. Two 20-watt halogen puck lights with switch are included.

Door Overhead Single Binder Height

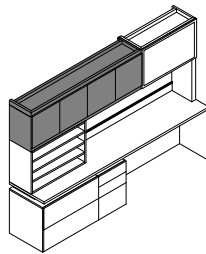

Glass Flip-up Overhead

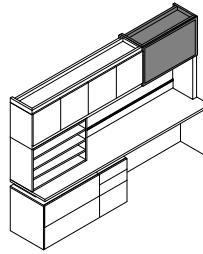

Glass Door Overhead

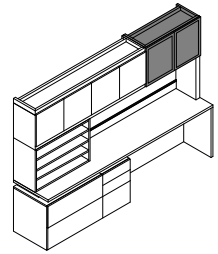

Door Overhead Double Binder Height

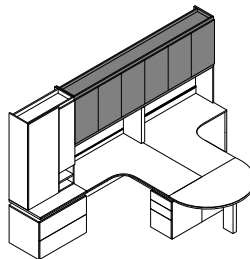

Wall Mount Accent Bookcase

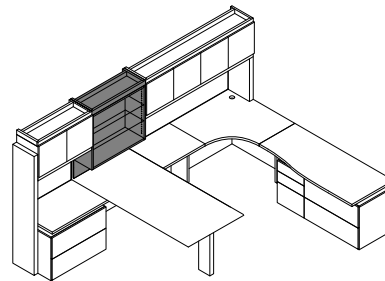

Worksurface Towers

Worksurface towers are designed for installation on credenzas, returns or other worksurfaces and may be used in combination with overheads and vertical storage for workwall applications. Available in two heights for use with single or double binder overheads in a combination of doors, drawers, and shelves with wood finish or paint finish options. Doors are available in wood or white, back-painted glass with aluminum trim. Glass doors are only available with the aluminum tab pull. Units with glass shelves have two 10-watt halogen puck lights with switch.

Double Door/Open Worksurface Tower

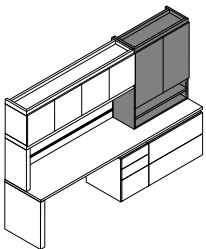

Door Worksurface Tower

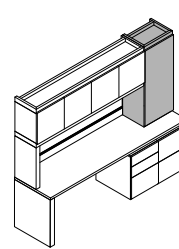

Single Door/Open Worksurface Tower

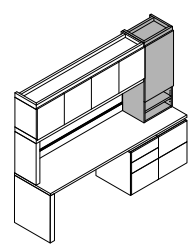

Vertical Storage

Vertical storage is available in varying heights and depths corresponding to work wall height and depth. Units can be ganged to form a storage wall, used in combinations with overheads and worksurface towers for workcenters, or serve as freestanding units. Available in combinations of doors, drawers and shelf units. Some units are available with back-painted white glass doors. Glass doors are aluminum trimmed and are available only with the aluminum tab pull. Pulls, locks and levelers are included. File bars and rails to accommodate letter, legal, A-4 and foolscap filing are included in vertical storage with file drawers.

Accent vertical storage is also available in a 52" height for use under overheads or as a freestanding unit.

Door/Drawer Vertical Storage Aligns with Worksurfaces

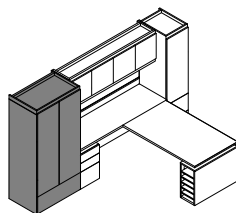

Open Vertical Storage Aligns with Overhead Units

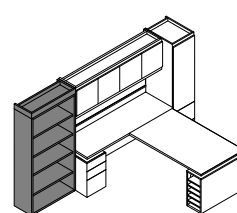

Door Accent Vertical Storage Cabinet Supports Overhead Units and Aligns with Worksurfaces

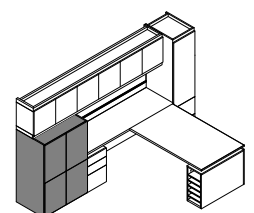

Tackboards

Aluminum trimmed, fabric covered tackboards are available for use with overheads and worksurface towers. Available in a variety of sizes to fit between combinations of panels and support options. Tackboards have a 1 1/2" d aluminum frame with 1/2" lip showing on the front and attaches to the worksurface. A fabric wrapped tackboard is inserted into the frame.

Tackboards may be used with or without an accessory rail. Accessory rails must be specified separately. See page 65 for accessory rail skus. Specify Bernhardt Textiles fabric or provide COM for covering tackboards. See page 3 for application information and COM shipping instructions. Hardware for connection to overheads and worksurface towers is included. See page 50 and 51 for tackboard skus.

Tackboard Side View

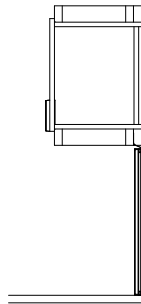

Tackboard with Accessory Rail Side View

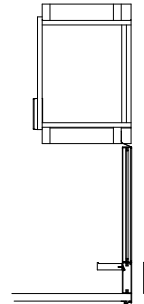

Accessory Rail

Designed from extruded aluminum, the accessory rail attaches to worksurfaces and provides a track for accessories with appropriate mounting hardware. Accessories can be added, removed and moved along the accessory rail as needed. The rail may be used independently or with a tackboard. When used with a tackboard, the rail is inserted into a 1 1/2" d aluminum frame with the fabric covered tackboard. A variety of accessories are available for use with the accessory rail. See pages 62 and 63 for accessory options.

Accessory Rail with Accessory Shelf

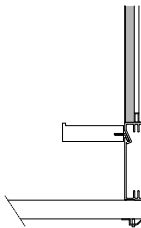

Tackboard with Accessory Rail

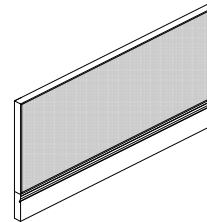

Accessories

Designed to attach to the accessory rail or as independent units. All of the accessories are modular in that they can be added, removed and moved along the accessory rail as needed. The ceramic accents are custom produced by hand from Lennox and are only available in white.

Paper trays are formed, solid white acrylic shelves attached to a frame. Available only in pairs in letter or legal sizes.

Wood storage boxes are designed to hold CD's, notepads and other miscellaneous items. Available with or without a white ceramic pencil holder.

Wood accessory shelves are 1" thick maple with a variety of cut-outs and recesses for the ceramic accessories. The accessories include: a 3" x 5/8" h clip cup, an 8 3/4" l x 4" w x 1 1/4" h oval dish, a 3 3/4" l x 3 1/2" w x 2 1/2" h box with lid, and a 2" w x 5" h vase. Ceramic accessories are included with the shelves as shown on page 62 and 63. Available in 24" and 30" lengths.

Paper Tray

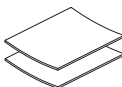

Accessory Box with Pencil Holder

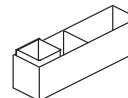

Wood Accessory Shelf with Ceramic Accessories

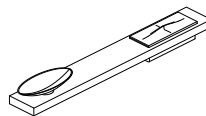

Communication Grommets

The communication grommet is inserted into a worksurface to allow the passage of wires through the surface to a power or communication source beneath. The units easily open to provide wire passage. Available in a standard 3" round, die cast zinc with brushed aluminum finish or a 9" length in anodized aluminum or wood veneer finish. The 9" communication grommet may be used in conjunction with the power module and with wood or fabric access back panels.

The position along the length of the top must be specified on the purchase order when ordering the worksurface top. When specifying the communication grommet in a worksurface, standard locations are left, right, both right and left, or center. See page 7 for grommet placement selections. The placement of a communication grommet must be in an open kneewell for maximum effectiveness and to provide clearance to access the power and communication devices. Custom locations may be accomplished by providing a sketch with dimensions with your request for quote and your purchase order. The exact placement of the grommet must be specified on the purchase order. Grommets cannot be changed or added after an order is acknowledged and entered into production.

NOTE: For field installation of a 3" grommet, a 2 1/2" diameter cutout is required.

9" Communication Grommet

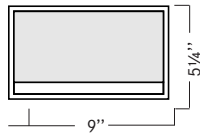

Communication Grommet
Brushed Aluminum Finish

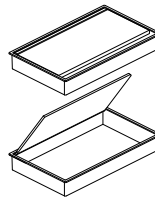

Communication Grommet
Wood Veneer Finish

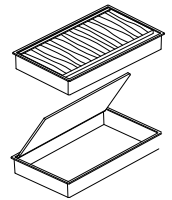
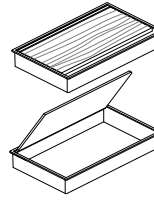

VFD Grain Long

VFE Grain Short

3" Standard Grommet

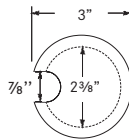

Standard Grommet
Anodized Aluminum Finish



Power Module

The power module is an interconnect device for installation in a worksurface with the 9" communication grommet. The power module integrates the need for grounded convenient receptacles for electronic and communication needs. Each power module will include four grounded outlets with one rotated to accept a power brick transformer; 120 volt; 60 HZ; 15 amp with integrated switch and breaker; 9' 14-gauge grounded plug or 6'-0 hardwire whip that must be installed by your communications technician. Two category 5 RJ45 communication/data jacks with 13' category 5 cable jacks by AMP can easily be removed on site if other manufacturers jacks are required. Overall size of power module is 9"w x 14 3/4"d by 3 1/2" h.

Power Module

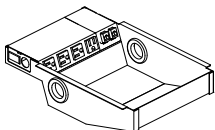

Power Module Installed in Worksurface

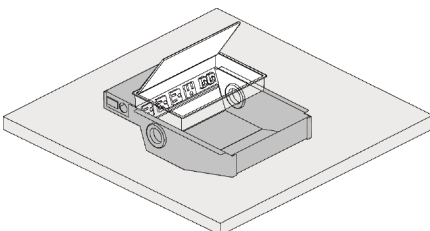

Power Harness

The Shift power harness is designed to work with the wood access back panel or as an independent component. The VEP harness consists of five grounded outlets, a 15 amp circuit breaker, a rocker switch and 9 feet of 15 amp power cord. The VEA harness consists of two grounded outlets that can be used for standard or dedicated power with a ten foot, 15 amp cord. Both units are UL listed and CSA certified for permanent installation. Rated for 120 volt, 60Hz at 15 amps.

Power Harness

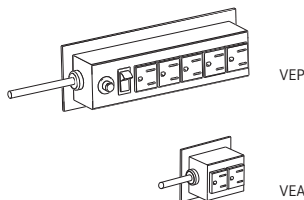

Wire Manager

A section of black vinyl that contains and routes wires under a worksurface. Mounting screws are included. Available in 24", 30" and 36" lengths.

Wire Manager

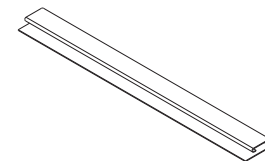

Wire Clip

A molded nylon component that screws to the bottom of a worksurface and holds 2 - 4 wires in place. Packaged in sets of four along with mounting screws. 1"w x 1"d x 7/8"h.

Wire Clip



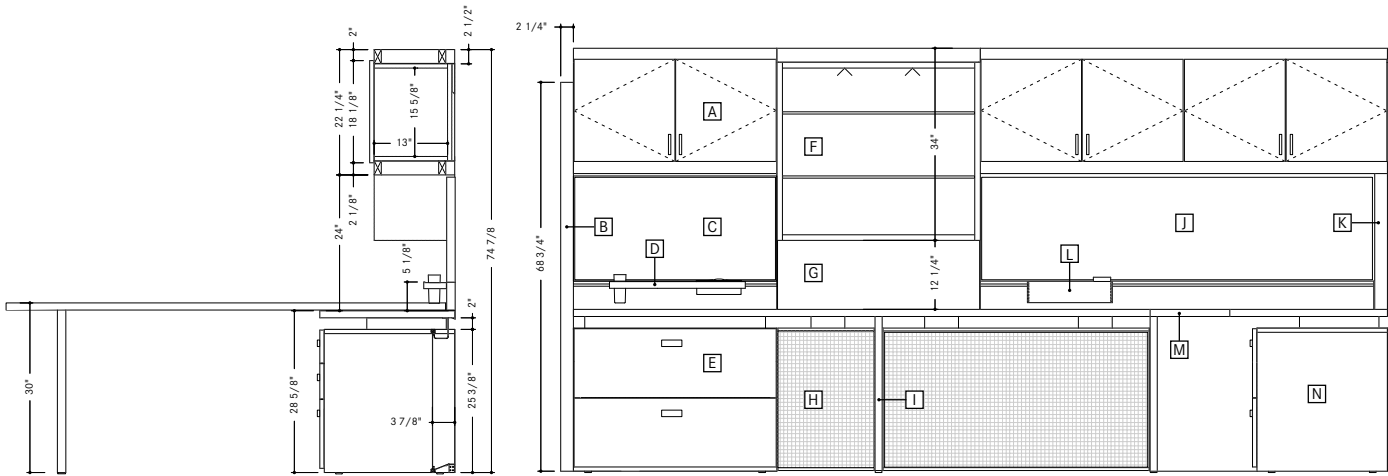

- A** Door Overhead
- B** Overhead End Support Panel
- C** Tackboard with Accessory Rail
- D** Wood Accessory Shelf Rail
- E** FF Drawer Lateral
- F** Wall Mount Accent Overhead
- G** Filler Panel
- H** Fabric Access Back Panel
- I** Mid-Support Panel
- J** Tackboard with Accessory Rail
- K** Overhead Worksurface Support - Right
- L** Wood Storage Box with Pencil Holder
- M** Worksurface Top
- N** FF Drawer Pedestal

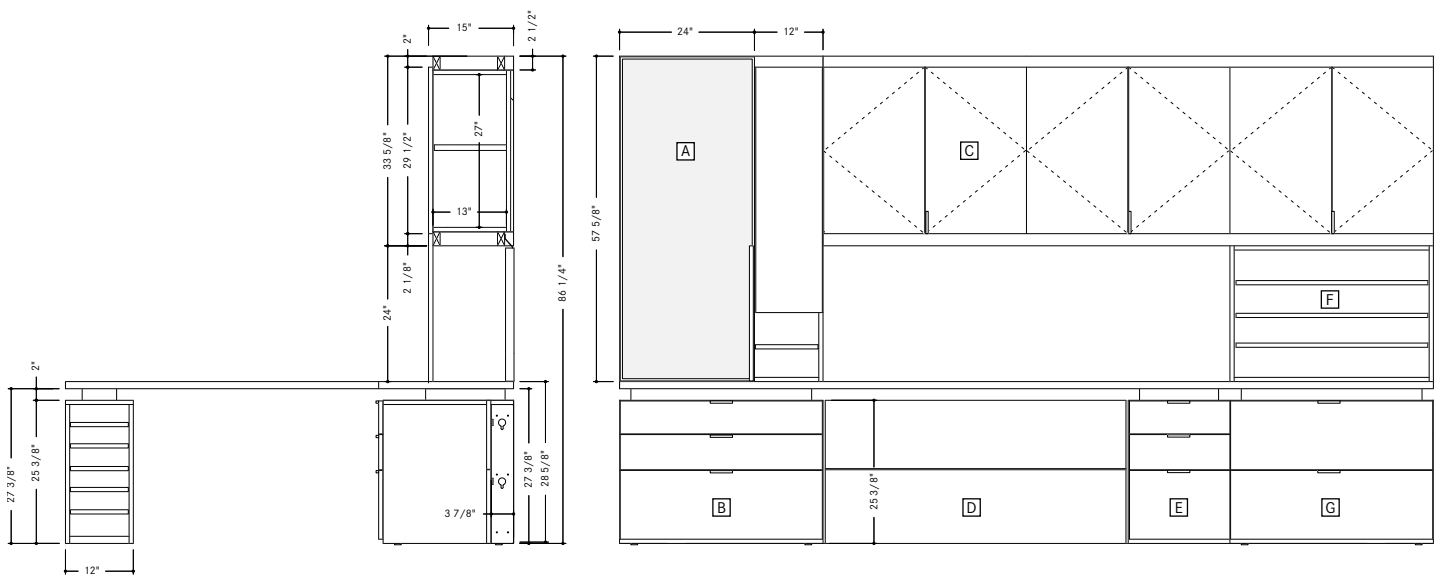

- A** Door/Open Worksurface Tower
- B** BBF Drawer Lateral
- C** Door Overhead
- D** Wood Access Back Panel
- E** BBF Drawer Pedestal
- F** Overhead Worksurface Support Organizer
- G** FF Drawer Lateral

Preferred Carrier Guaranteed Freight Rates

Freight charges will be applied to orders as a separate line item based on the zones listed.

The freight amount is calculated on the total merchandise net COM price, excluding any extra discounts beyond standard net pricing. Additional freight fuel surcharges may apply.

All orders are shipped by Bernhardt Design company trucks or preferred carriers specified by Bernhardt Design.

Rates are based on deliveries made Monday through Friday, 8 a.m. until 5 p.m. Dealer warehouse information, including phone number and contact name, must be specified on the purchase order. Direct site deliveries may be requested with an additional freight cost.

Bernhardt Design freight rates are based on the following zones with a minimum for each zone. All zones are within the Continental United States.

Bernhardt Design freight rates are based on the following zones with a minimum for each zone. All zones are within the Continental United States.

Zone	Minimum Charge	Freight Rate
1	\$90	7%
2	\$90	8%
3	\$90	9%
4	\$110	11%
5	\$120	13%
6	\$120	15%

Exceptions: Special freight rates are applicable to certain designated geographic areas as listed below. For information, please contact your local Bernhardt Design sales representative.

Zone	Minimum Charge	Area	Freight Rate
1	\$90	Charlotte, NC	5%
		Columbia, SC	6%
		Greensboro, NC	5%
		Greenville, SC	5%
		Raleigh, NC	5%
		Winston Salem, NC	5%
2	\$90	Atlanta, GA	7%
		Washington, DC	6%
		Boston, MA	8%
3	\$90	Jacksonville, FL	8%
		Manhattan/City	7%
		Philadelphia, PA	8%
		St. Petersburg, FL	8%
		Tampa, FL	8%
		Dallas, TX	10%
		Kansas City, KS	10%
		Minneapolis, MN	10%
		Denver, CO	12%
		Las Vegas, NV	11%
4	\$110	Los Angeles, CA	11%
		Phoenix, AZ	11%
		Reno, NV	12%
		Salt Lake City, UT	12%
		San Francisco, CA	12%

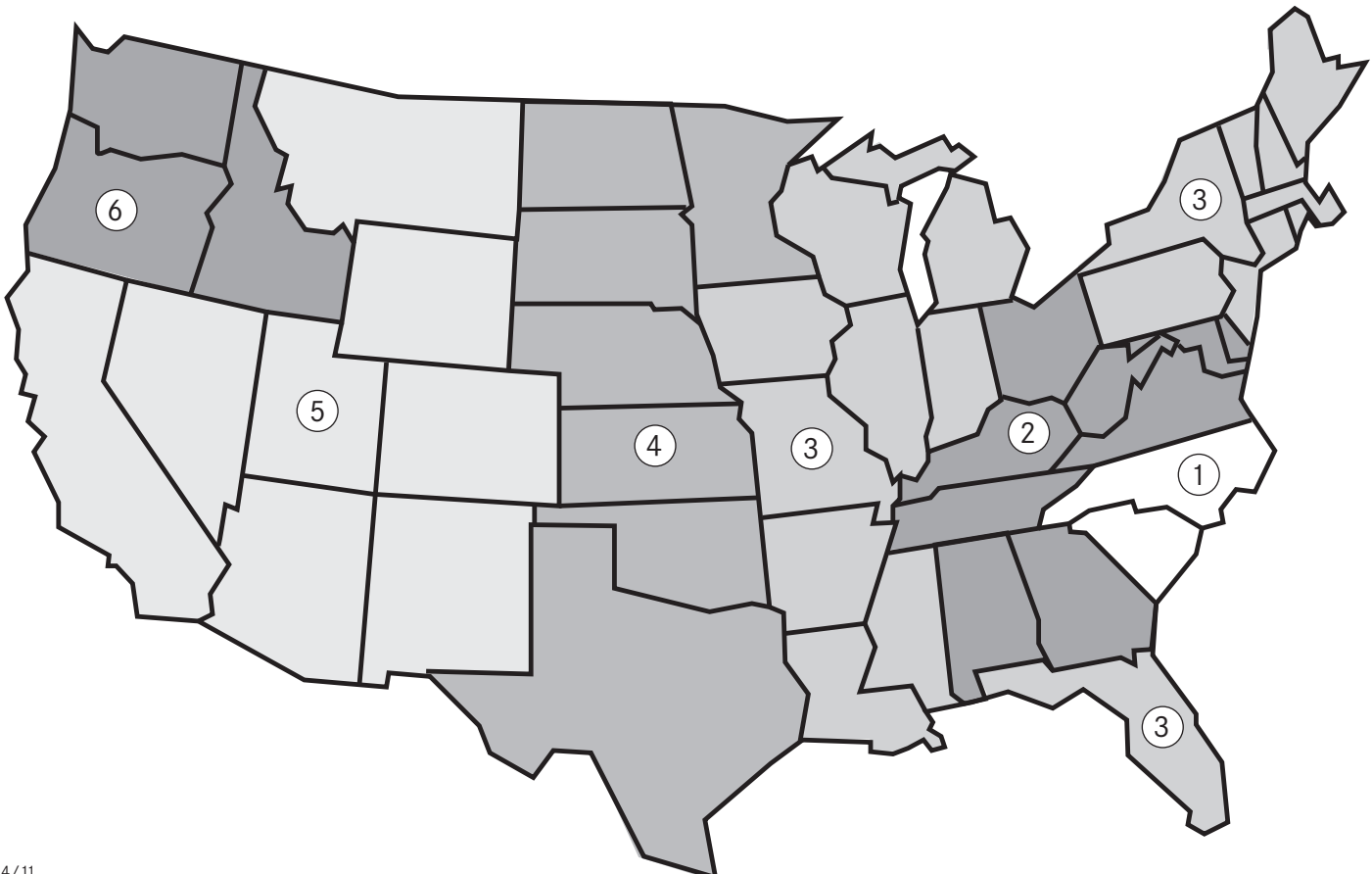

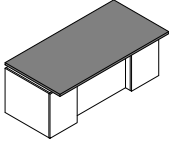
description	sku	w	d	h	weight	specifications	grade 1	grade 2
 <p>rectangular desk top overhanging top for pedestal desk edge styles available: <input type="checkbox"/> flat wood 4 sides <input type="checkbox"/> metal 4 sides <input type="checkbox"/> shaped wood user and guest sides only</p>	AAW	72	30	1¼	100	use with 23% ^d pedestal specify 68w flush panel or 36w recessed panel	\$ 1437	\$ 1648
	AAR	72	36	1¼	105	use with 28% ^d pedestal specify 68w flush panel or 36w recessed panel	1620	1857
	AAQ	78	36	1¼	110	use with 28% ^d pedestal specify 74w flush panel or 42w recessed panel	1743	1998
	AAP	84	36	1¼	120	use with 28% ^d pedestal specify 80w flush panel or 48w recessed panel	1868	2283

specification codes

reference page 8 for product details

series

W wood veneer

W

sku

veneer

grade 1
 J cherry
 W walnut
 E maple
grade 2
 Q anigre

style

F flat edge
 M metal edge
 S shaped edge

pull/hardware

X none

X

finish

see page 7

grommet

1 3" left
 2 3" right
 3 3" both
 4 3" center
 X none
 3" grommet/\$65 each

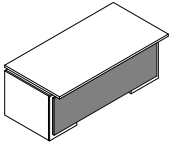
description	sku	w	d	h	weight	specifications	grade 1	grade 2
 <p>flush modesty panel</p> <p>use with desk pedestals for flush modesty panel desk</p>	8FD	68	1	22 ³ / ₈	100	use with 72w top	\$ 995	\$ 1097
	8FE	74	1	22 ³ / ₈	105	use with 78w top	1031	1182
	8FF	80	1	22 ³ / ₈	110	use with 84w top	1147	1317

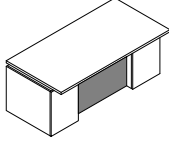
 <p>recessed modesty panel</p> <p>use with desk pedestals for recessed modesty panel desk</p>	8GD	36	3/4	22 ³ / ₈	65	use with 72w top	523	600
	8GE	42	3/4	22 ³ / ₈	75	use with 78w top	610	699
	8GF	48	3/4	22 ³ / ₈	85	use with 84w top	706	807

specification codes

reference page 8
for product details

series

- W wood veneer
- P paint

sku

--	--	--	--

veneer

- grade 1
 - paint
 - cherry
 - walnut
 - maple
- grade 2
 - anigre

style

- none

pull/hardware

- none

finish

see page 7

--	--	--	--

grommet

- none

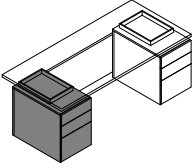
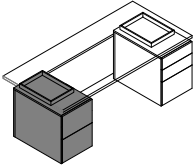
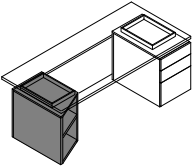
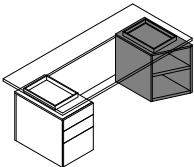
description	sku	w	d	h	weight	specifications	grade 1	grade 2
 <p>desk pedestal for flush modesty panel</p> <p>BBF finished back for right or left installation specify two pedestals for desk 1 lock</p>	MKQ	18	24 $\frac{5}{8}$	27 $\frac{3}{8}$	110	use with 30d rectangular top	\$ 1608	\$ 1844
	MKP	18	29 $\frac{5}{8}$	27 $\frac{3}{8}$	130	use with 36d rectangular top	1646	1886
 <p>desk pedestal for flush modesty panel</p> <p>FF finished back for right or left installation specify two pedestals for desk 1 lock</p>	MUQ	18	24 $\frac{5}{8}$	27 $\frac{3}{8}$	105	use with 30d rectangular top	1686	1931
	MUP	18	29 $\frac{5}{8}$	27 $\frac{3}{8}$	125	use with 36d rectangular top	1722	1973
 <p>left shelf pedestal for flush modesty panel</p> <p>adjustable organizer shelf finished back for user left installation specify with BBF or FF pedestal for desk use with an L or U configuration</p>	MD9	18	24 $\frac{5}{8}$	27 $\frac{3}{8}$	130	use with 30d rectangular top	1259	1442
	MD8	18	29 $\frac{5}{8}$	27 $\frac{3}{8}$	145	use with 36d rectangular top	1295	1533
 <p>right shelf pedestal for flush modesty panel</p> <p>adjustable organizer shelf finished back for user right installation specify with BBF or FF pedestal for desk use with an L or U configuration</p>	MD7	18	24 $\frac{5}{8}$	27 $\frac{3}{8}$	130	use with 30d rectangular top	1259	1442
	MD6	18	29 $\frac{5}{8}$	27 $\frac{3}{8}$	145	use with 36d rectangular top	1295	1533

specification codes	series	sku	veneer	style	pull/hardware	finish	grommet
reference page 8 for product details	<input checked="" type="checkbox"/> wood veneer <input type="checkbox"/> paint		grade 1 <input checked="" type="checkbox"/> paint <input type="checkbox"/> cherry <input type="checkbox"/> walnut <input type="checkbox"/> maple grade 2 <input type="checkbox"/> anigre	<input checked="" type="checkbox"/> none	<input type="checkbox"/> aluminum tab <input type="checkbox"/> ecru leather <input checked="" type="checkbox"/> none	see page 7	<input checked="" type="checkbox"/> none
				<input checked="" type="checkbox"/>			<input checked="" type="checkbox"/>

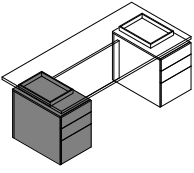
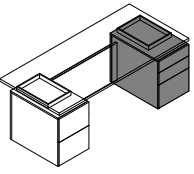
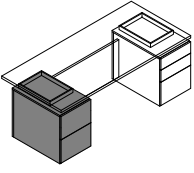
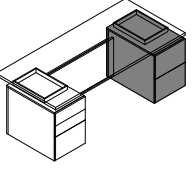
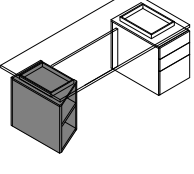
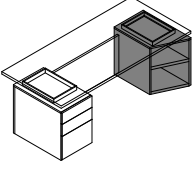
	description	sku	w	d	h	weight	specifications	grade 1	grade 2
	left desk pedestal for recessed modesty panel BBF finished back for user left installation specify two pedestals for desk 1 lock	MIQ	18	24 $\frac{5}{8}$	27 $\frac{3}{8}$	110	use with 30d rectangular top	\$ 1608	\$ 1844
		MIP	18	29 $\frac{5}{8}$	27 $\frac{3}{8}$	130	use with 36d rectangular top	1646	1886
	right desk pedestal for recessed modesty panel BBF finished back for user right installation specify two pedestals for desk 1 lock	MSQ	18	24 $\frac{5}{8}$	27 $\frac{3}{8}$	110	use with 30d rectangular top	1608	1844
		MSP	18	29 $\frac{5}{8}$	27 $\frac{3}{8}$	130	use with 36d rectangular top	1646	1886
	left desk pedestal for recessed modesty panel FF finished back for user left installation specify two pedestals for desk 1 lock	MGQ	18	24 $\frac{5}{8}$	27 $\frac{3}{8}$	105	use with 30d rectangular top	1686	1931
		MGP	18	29 $\frac{5}{8}$	27 $\frac{3}{8}$	125	use with 36d rectangular top	1722	1973
	right desk pedestal for recessed modesty panel FF finished back for user right installation specify two pedestals for desk 1 lock	MTQ	18	24 $\frac{5}{8}$	27 $\frac{3}{8}$	105	use with 30d rectangular top	1686	1931
		MTP	18	29 $\frac{5}{8}$	27 $\frac{3}{8}$	125	use with 36d rectangular top	1722	1973
	left shelf pedestal for recessed modesty panel adjustable organizer shelf finished back for user left installation specify with BBF or FF pedestal for desk use with an L or U configuration	MS9	18	24 $\frac{5}{8}$	27 $\frac{3}{8}$	130	use with 30d rectangular top	1259	1442
		MS8	18	29 $\frac{5}{8}$	27 $\frac{3}{8}$	145	use with 36d rectangular top	1295	1533
	right shelf pedestal for recessed modesty panel adjustable organizer shelf finished back for user right installation specify with BBF or FF pedestal for desk use with an L or U configuration	MS7	18	24 $\frac{5}{8}$	27 $\frac{3}{8}$	130	use with 30d rectangular top	1259	1442
		MS6	18	29 $\frac{5}{8}$	27 $\frac{3}{8}$	145	use with 36d rectangular top	1295	1533

specification codes	series	sku	veneer	style	pull/hardware	finish	grommet
reference page 8 for product details	<input type="checkbox"/> wood veneer <input type="checkbox"/> paint		grade 1 <input checked="" type="checkbox"/> paint <input type="checkbox"/> cherry <input type="checkbox"/> walnut <input type="checkbox"/> maple grade 2 <input type="checkbox"/> anigre	<input checked="" type="checkbox"/> none	<input type="checkbox"/> aluminum tab <input type="checkbox"/> ecru leather <input checked="" type="checkbox"/> none	see page 7	<input checked="" type="checkbox"/> none
				<input checked="" type="checkbox"/>			<input checked="" type="checkbox"/>

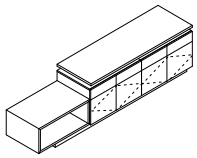
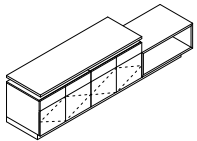
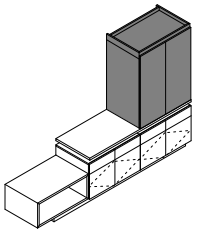
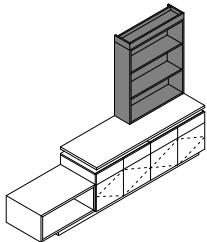
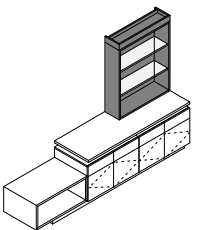
	description	sku	w	d	h	weight	specifications	grade 1	grade 2
	<p>conference room accent credenza</p> <p>open storage compartment on left four doors four drawers 3¾" recessed base no locks specify series code W specify style code F</p>	IBR	108	23¾	28½	420		\$ 5974	\$ 6850
	<p>conference room accent credenza</p> <p>open storage compartment on right four doors four drawers 3¾" recessed base no locks specify series code W specify style code F</p>	IBW	108	23¾	28½	420		5974	6850
	<p>storage tower</p> <p>wood doors 2 adjustable shelves specify style code X</p>	SBU	36	23¾	46¼	300		4642	5321
	<p>open accent credenza tower</p> <p>wood shelves 2 adjustable shelves specify style code X specify pull/hardware code X</p>	Q6Y	36	14¼	46¼	255		2857	3283
	<p>open accent credenza tower</p> <p>glass shelves two 20-watt halogen lights with switch specify style code X specify pull/hardware code X</p>	Q7Y	36	14¼	46¼	255		3908	4480

specification codes	series	sku	veener	style	pull/hardware	finish	grommet
<p><input type="checkbox"/> W wood veneer</p> <p><input type="checkbox"/> P paint</p>			<p>grade 1</p> <p><input checked="" type="checkbox"/> X paint</p> <p><input type="checkbox"/> J cherry</p> <p><input type="checkbox"/> 9 walnut</p> <p><input type="checkbox"/> E maple</p> <p>grade 2</p> <p><input type="checkbox"/> Q anigre</p>	<p><input type="checkbox"/> F flat edge</p> <p><input checked="" type="checkbox"/> X none</p>	<p><input type="checkbox"/> 7 aluminum tab</p> <p><input type="checkbox"/> 9 ecru leather</p> <p><input checked="" type="checkbox"/> X none</p>	<p>see page 7</p>	<p><input checked="" type="checkbox"/> X none</p>
							<input checked="" type="checkbox"/> X

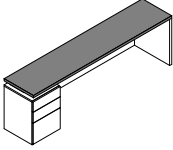
description	sku	w	d	h	weight	specifications	grade 1	grade 2
 <p>credenza top 18 7/8" deep edge styles available: <input type="checkbox"/> flat wood 4 sides <input type="checkbox"/> metal 4 sides <input type="checkbox"/> shaped wood front only d 19 3/8"</p>	4BV	30	18 7/8	1 1/4	65		\$ 638	\$ 728
	4BU	36	18 7/8	1 1/4	70		685	784
	4BT	42	18 7/8	1 1/4	75		735	843
	4BS	48	18 7/8	1 1/4	80		784	898
	4BR	54	18 7/8	1 1/4	85		834	956
	4BQ	60	18 7/8	1 1/4	90		882	1011
	4BP	66	18 7/8	1 1/4	95		930	1065
	4BN	72	18 7/8	1 1/4	105		978	1121
	4BM	78	18 7/8	1 1/4	110		1025	1177
	4BL	84	18 7/8	1 1/4	120		1077	1234
	4BK	90	18 7/8	1 1/4	125		1124	1289
	4BJ	96	18 7/8	1 1/4	130		1173	1345
	4BI	102	18 7/8	1 1/4	145		1300	1492
	4BH	108	18 7/8	1 1/4	155		1349	1548
	4BG	114	18 7/8	1 1/4	165		1404	1609
	4BF	120	18 7/8	1 1/4	175		1454	1666

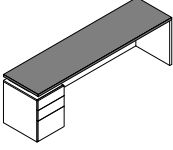
 <p>credenza top 23 3/8" deep edge styles available: <input type="checkbox"/> flat wood 4 sides <input type="checkbox"/> metal 4 sides <input type="checkbox"/> shaped wood front only d 24 3/8"</p>	5BV	30	23 3/8	1 1/4	75		674	774
	5BU	36	23 3/8	1 1/4	80		709	812
	5BT	42	23 3/8	1 1/4	85		774	887
	5BS	48	23 3/8	1 1/4	90		824	944
	5BR	54	23 3/8	1 1/4	95		872	999
	5BQ	60	23 3/8	1 1/4	100		921	1056
	5BP	66	23 3/8	1 1/4	105		951	1091
	5BN	72	23 3/8	1 1/4	115		1024	1174
	5BM	78	23 3/8	1 1/4	120		1066	1224
	5BL	84	23 3/8	1 1/4	130		1116	1279
	5BK	90	23 3/8	1 1/4	135		1172	1344
	5BJ	96	23 3/8	1 1/4	140		1213	1391
	5BI	102	23 3/8	1 1/4	155		1342	1537
	5BH	108	23 3/8	1 1/4	165		1390	1594
	5BG	114	23 3/8	1 1/4	175		1446	1656
	5BF	120	23 3/8	1 1/4	185		1494	1714

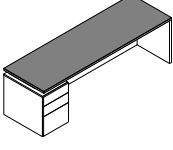
 <p>credenza top 28 3/8" deep edge styles available: <input type="checkbox"/> flat wood 4 sides <input type="checkbox"/> metal 4 sides <input type="checkbox"/> shaped wood front only d 29 3/8"</p>	6BV	30	28 3/8	1 1/4	80		783	898
	6BU	36	28 3/8	1 1/4	85		834	956
	6BT	42	28 3/8	1 1/4	90		882	1011
	6BS	48	28 3/8	1 1/4	95		930	1065
	6BR	54	28 3/8	1 1/4	100		979	1122
	6BQ	60	28 3/8	1 1/4	105		1029	1178
	6BP	66	28 3/8	1 1/4	110		1076	1235
	6BN	72	28 3/8	1 1/4	115		1124	1289
	6BM	78	28 3/8	1 1/4	125		1173	1345
	6BL	84	28 3/8	1 1/4	130		1225	1404
	6BK	90	28 3/8	1 1/4	140		1270	1590
	6BJ	96	28 3/8	1 1/4	145		1320	1513
	6BI	102	28 3/8	1 1/4	150		1437	1532
	6BH	108	28 3/8	1 1/4	165		1507	1728
	6BG	114	28 3/8	1 1/4	185		1559	1764
	6BF	120	28 3/8	1 1/4	195		1609	1845

specification codes	series	sku	veneer	style	pull/hardware	finish	grommet placement
	<input type="checkbox"/> wood veneer		grade 1 <input type="checkbox"/> cherry <input type="checkbox"/> walnut <input type="checkbox"/> maple grade 2 <input type="checkbox"/> anigre	<input type="checkbox"/> flat edge <input type="checkbox"/> metal edge <input type="checkbox"/> shaped edge	<input checked="" type="checkbox"/> none	see page 7	<input type="checkbox"/> 3" left <input type="checkbox"/> 9" left <input type="checkbox"/> 3" right <input type="checkbox"/> 9" right <input type="checkbox"/> 3" both <input type="checkbox"/> 9" both <input type="checkbox"/> 3" center <input type="checkbox"/> 9" center <input type="checkbox"/> none 3" grommet/\$65 each 9" grommet specify separately see page 59
	<input type="checkbox"/>	<input type="checkbox"/>	<input type="checkbox"/>	<input type="checkbox"/>	<input type="checkbox"/>	<input type="checkbox"/>	<input type="checkbox"/>

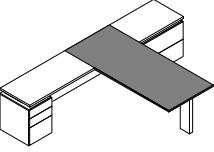
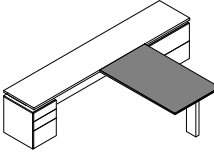
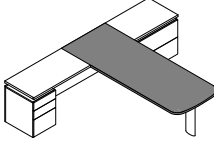
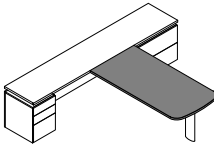
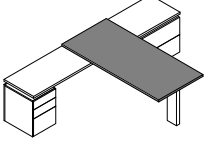
description	sku	w	d	h	weight	specifications	grade 1	grade 2
 <p>rectangular peninsula top</p> <p>edge styles available:</p> <p><input type="checkbox"/> flat wood 4 sides</p> <p><input type="checkbox"/> metal 4 sides</p> <p><input type="checkbox"/> shaped wood 3 sides flat end</p>	2BY	66	30	1¼	85		\$ 1318	\$ 1510
	2BW	72	30	1¼	95		1437	1648
	2BR	72	36	1¼	110		1620	1857
	2BQ	78	36	1¼	120		1743	1998
	2BP	84	36	1¼	130		1868	2141
	2BC	90	36	1¼	140		1992	2283
 <p>rectangular peninsula top</p> <p>edge styles available:</p> <p><input type="checkbox"/> flat wood 4 sides</p> <p><input type="checkbox"/> metal 4 sides</p> <p><input type="checkbox"/> shaped wood 3 sides coped end</p>	2LZ	60	30	1¼	80		1217	1398
	2LY	66	30	1¼	85		1318	1520
	2LW	72	30	1¼	95		1581	1832
	2LT	60	36	1¼	90		1390	1592
	2LS	66	36	1¼	100		1506	1727
	2LR	72	36	1¼	110		1626	1865
 <p>arched shaped peninsula top</p> <p>edge styles available:</p> <p><input type="checkbox"/> flat wood 4 sides</p> <p><input type="checkbox"/> not available</p> <p><input type="checkbox"/> shaped wood 3 sides flat end</p>	2DV	66	30	1¼	85		1955	2240
	2DU	72	30	1¼	95		2006	2299
	2DP	72	36	1¼	105		2121	2430
	2DC	78	36	1¼	115		2168	2486
	2DD	84	36	1¼	125		2218	2542
	2DQ	90	36	1¼	135		2329	2656
 <p>arched shaped peninsula top</p> <p>edge styles available:</p> <p><input type="checkbox"/> flat wood 4 sides</p> <p><input type="checkbox"/> not available</p> <p><input type="checkbox"/> shaped wood 3 sides coped end</p>	2PZ	60	30	1¼	80		1520	1743
	2PY	66	30	1¼	85		1646	1886
	2PW	72	30	1¼	95		2037	2336
	2PT	60	36	1¼	90		2049	2363
	2PS	66	36	1¼	100		2105	2411
	2PR	72	36	1¼	110		2158	2473
 <p>overlapping accent peninsula top</p> <p>specify series W for wood top</p> <p>specify series P for white back-painted glass top</p> <p>grommets not available with glass top</p> <p>edge styles available:</p> <p><input type="checkbox"/> metal 4 sides</p>	6EM	78	30	1¼	100		2351	2696
	6FM	78	36	1¼	120		2474	2865
	6GM	84	36	1¼	130		2623	3005
	6HM	90	36	1¼	140		2753	3155

specification codes	series	sku	veneer	style	pull/hardware	finish	grommet placement
	<input type="checkbox"/> wood veneer <input type="checkbox"/> painted glass		grade 1 <input type="checkbox"/> painted glass <input type="checkbox"/> cherry <input type="checkbox"/> walnut <input type="checkbox"/> maple grade 2 <input type="checkbox"/> anigre	<input type="checkbox"/> flat edge <input type="checkbox"/> metal edge <input type="checkbox"/> shaped edge	<input checked="" type="checkbox"/> none	see page 7	<input type="checkbox"/> 3" left <input type="checkbox"/> 9" left <input type="checkbox"/> 3" right <input type="checkbox"/> 9" right <input type="checkbox"/> 3" both <input type="checkbox"/> 9" both <input type="checkbox"/> 3" center <input type="checkbox"/> 9" center <input checked="" type="checkbox"/> none 3" grommet/\$65 each 9" grommet specify separately see page 59
					<input checked="" type="checkbox"/>		

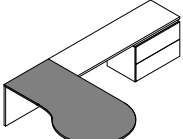
description	sku	w	d	h	weight	specifications	grade 1	grade 2
 <p>p-shape peninsula top left conference edge styles available: <input type="checkbox"/> flat wood 4 sides <input type="checkbox"/> not available <input type="checkbox"/> shaped wood 3 sides flat end</p>	2SW	72	30	1¼	140	42" end diameter	\$ 3414	\$ 3914
	2SV	78	30	1¼	150	42" end diameter	3570	4096
	2SR	72	36	1¼	145	48" end diameter	3666	4204
	2SQ	78	36	1¼	165	48" end diameter	3821	4382
	2SP	84	36	1¼	180	48" end diameter	3972	4555
	2SC	90	36	1¼	195	48" end diameter	4122	4727

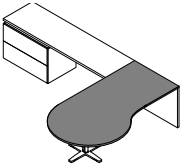
 <p>p-shape peninsula top right conference edge styles available: <input type="checkbox"/> flat wood 4 sides <input type="checkbox"/> not available <input type="checkbox"/> shaped wood 3 sides flat end</p>	2TW	72	30	1¼	140	42" end diameter	3414	3914
	2TV	78	30	1¼	155	42" end diameter	3570	4096
	2TR	72	36	1¼	145	48" end diameter	3666	4204
	2TQ	78	36	1¼	165	48" end diameter	3842	4382
	2TP	84	36	1¼	180	48" end diameter	3972	4555
	2TC	90	36	1¼	195	48" end diameter	4122	4727

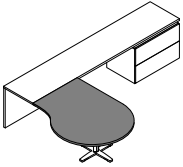
 <p>p-shape peninsula top left conference edge styles available: <input type="checkbox"/> flat wood 4 sides <input type="checkbox"/> not available <input type="checkbox"/> shaped wood 3 sides coped end</p>	2QZ	60	30	1¼	105	42" end diameter	3106	3561
	2QY	66	30	1¼	115	42" end diameter	3165	3629
	2QW	72	30	1¼	140	42" end diameter	3288	3771
	2QV	78	30	1¼	155	42" end diameter	3446	3952
	2QT	60	36	1¼	110	48" end diameter	3330	3819
	2QS	66	36	1¼	120	48" end diameter	3436	4020
	2QR	72	36	1¼	145	48" end diameter	3529	4046
	2QQ	78	36	1¼	165	48" end diameter	3697	4237

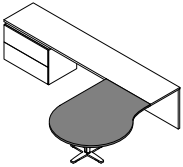
 <p>p-shape peninsula top right conference edge styles available: <input type="checkbox"/> flat wood 4 sides <input type="checkbox"/> not available <input type="checkbox"/> shaped wood 3 sides coped end</p>	2RZ	60	30	1¼	105	42" end diameter	3106	3561
	2RY	66	30	1¼	115	42" end diameter	3165	3629
	2RW	72	30	1¼	140	42" end diameter	3288	3771
	2RV	78	30	1¼	155	42" end diameter	3446	3952
	2RT	60	36	1¼	110	48" end diameter	3330	3819
	2RS	66	36	1¼	120	48" end diameter	3436	4020
	2RR	72	36	1¼	145	48" end diameter	3529	4026
	2RQ	78	36	1¼	165	48" end diameter	3697	4237

specification codes

series

wood veneer

sku

veneer

grade 1
 cherry
 walnut
 maple
 grade 2
 anigre

style

flat edge
 metal edge
 shaped edge

pull/hardware

none

finish

see page 7

grommet placement

3" left 9" left
 3" right 9" right
 3" both 9" both
 3" center 9" center
 none

3" grommet/\$65 each
9" grommet specify separately
see page 59

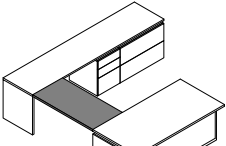
description	sku	w	d	h	weight	specifications	grade 1	grade 2
 <p>bridge top</p> <p>installation hardware included</p> <p>edge styles available:</p> <p><input type="checkbox"/> flat wood 4 sides</p> <p><input type="checkbox"/> metal 4 sides</p> <p><input type="checkbox"/> shaped wood front only coped ends</p>	GFV	37	18 ⁷ / ₈	1 ¹ / ₄	45	use with 37w back panel	\$ 654	\$ 750
	GFU	43	18 ⁷ / ₈	1 ¹ / ₄	55	use with 43w back panel	690	791
	GFT	49	18 ⁷ / ₈	1 ¹ / ₄	65	use with 49w back panel	724	829
	GFM	37	23 ⁷ / ₈	1 ¹ / ₄	55	use with 37w back panel	682	780
	GFL	43	23 ⁷ / ₈	1 ¹ / ₄	65	use with 43w back panel	714	820
	GFK	49	23 ⁷ / ₈	1 ¹ / ₄	75	use with 49w back panel	751	861

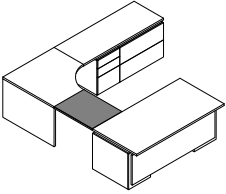
 <p>bridge top</p> <p>installation hardware included</p> <p>edge styles available:</p> <p><input type="checkbox"/> flat wood 4 sides</p> <p><input type="checkbox"/> metal 4 sides</p> <p><input type="checkbox"/> shaped wood front coped left/flat right</p>	GGP	25	23 ⁷ / ₈	1 ¹ / ₄	35	use with 25w back panel	601	689
	GGN	31	23 ⁷ / ₈	1 ¹ / ₄	45	use with 31w back panel	638	728
	GGM	37	23 ⁷ / ₈	1 ¹ / ₄	55	use with 37w back panel	670	770

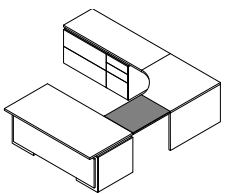
 <p>bridge top</p> <p>installation hardware included</p> <p>edge styles available:</p> <p><input type="checkbox"/> flat wood 4 sides</p> <p><input type="checkbox"/> metal 4 sides</p> <p><input type="checkbox"/> shaped wood front coped right/flat left</p>	GHP	25	23 ⁷ / ₈	1 ¹ / ₄	35	use with 25w back panel	601	689
	GHN	31	23 ⁷ / ₈	1 ¹ / ₄	45	use with 31w back panel	638	728
	GHM	37	23 ⁷ / ₈	1 ¹ / ₄	55	use with 37w back panel	670	770

specification codes	series	sku	veneer	style	pull/hardware	finish	grommet placement
	<input type="checkbox"/> wood veneer		grade 1 <input type="checkbox"/> cherry <input type="checkbox"/> walnut <input type="checkbox"/> maple grade 2 <input type="checkbox"/> anigre	<input type="checkbox"/> flat edge <input type="checkbox"/> metal edge <input type="checkbox"/> shaped edge	<input checked="" type="checkbox"/> none	see page 7	<input type="checkbox"/> 3" left <input type="checkbox"/> 9" left <input type="checkbox"/> 3" right <input type="checkbox"/> 9" right <input type="checkbox"/> 3" both <input type="checkbox"/> 9" both <input type="checkbox"/> 3" center <input type="checkbox"/> 9" center <input checked="" type="checkbox"/> none 3" grommet/\$65each 9" grommet specify separately see page 59
	<input type="checkbox"/>	<input type="checkbox"/>	<input type="checkbox"/>	<input type="checkbox"/>	<input checked="" type="checkbox"/>	<input type="checkbox"/>	<input type="checkbox"/>

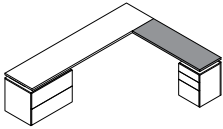
description	sku	w	d	h	weight	specifications	grade 1	grade 2
 <p>return top 18 7/8" deep installation hardware included edge styles available: <input type="checkbox"/> flat wood 4 sides <input type="checkbox"/> flat metal 4 sides</p>	4BU	36	18 7/8	1 1/4	45		\$ 685	\$ 784
	4BT	42	18 7/8	1 1/4	55		735	843
	4BS	48	18 7/8	1 1/4	65		784	898
	4BR	54	18 7/8	1 1/4	75		834	956
	4BQ	60	18 7/8	1 1/4	85		882	1011
	4BP	66	18 7/8	1 1/4	90		930	1065
	4BN	72	18 7/8	1 1/4	95		978	1121

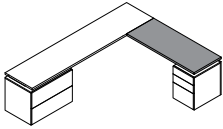
 <p>return top 23 3/8" deep installation hardware included edge styles available: <input type="checkbox"/> flat wood 4 sides <input type="checkbox"/> flat metal 4 sides</p>	5BU	36	23 3/8	1 1/4	55		709	812
	5BT	42	23 3/8	1 1/4	65		774	886
	5BS	48	23 3/8	1 1/4	75		824	944
	5BR	54	23 3/8	1 1/4	85		872	999
	5BQ	60	23 3/8	1 1/4	95		921	1056
	5BP	66	23 3/8	1 1/4	100		951	1091
	5BN	72	23 3/8	1 1/4	105		1024	1174

specification codes	series	sku	veener	style	pull/hardware	finish	grommet placement
	<input type="checkbox"/> wood veneer		grade 1 <input type="checkbox"/> cherry <input type="checkbox"/> walnut <input type="checkbox"/> maple grade 2 <input type="checkbox"/> anigre	<input type="checkbox"/> flat edge <input type="checkbox"/> metal edge	<input type="checkbox"/> none	see page 7	<input type="checkbox"/> 3" left <input type="checkbox"/> 9" left <input type="checkbox"/> 3" right <input type="checkbox"/> 9" right <input type="checkbox"/> 3" both <input type="checkbox"/> 9" both <input type="checkbox"/> 3" center <input type="checkbox"/> 9" center <input type="checkbox"/> none 3" grommet/\$65 each 9" grommet specify separately see page 59
	<input type="checkbox"/>	<input type="checkbox"/>	<input type="checkbox"/>	<input type="checkbox"/>	<input type="checkbox"/>	<input type="checkbox"/>	<input type="checkbox"/>

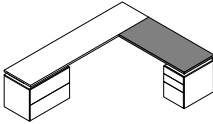
description	sku	w	d	h	weight	specifications	grade 1	grade 2
 <p>return top 19 3/8" deep installation hardware included edge styles available: <input type="checkbox"/> shaped wood front coped left/flat right</p>	3HV	36	19 3/8	1 1/4	45		\$ 575	\$ 670
	3HU	42	19 3/8	1 1/4	55		609	712
	3HT	48	19 3/8	1 1/4	65		645	753
	3HS	54	19 3/8	1 1/4	75		682	795
	3HR	60	19 3/8	1 1/4	85		717	833
	3HQ	66	19 3/8	1 1/4	90		751	878
	3HP	72	19 3/8	1 1/4	95		786	916

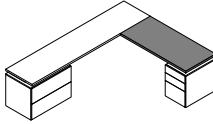
 <p>return top 24 3/8" deep installation hardware included edge styles available: <input type="checkbox"/> shaped wood front coped left/flat right</p>	3HM	36	24 3/8	1 1/4	55		602	701
	3HL	42	24 3/8	1 1/4	65		638	742
	3HK	48	24 3/8	1 1/4	75		671	782
	3HJ	54	24 3/8	1 1/4	85		709	826
	3HH	60	24 3/8	1 1/4	95		745	869
	3HG	66	24 3/8	1 1/4	100		779	908
	3HF	72	24 3/8	1 1/4	105		818	956

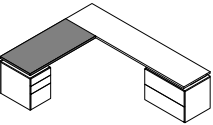
 <p>return top 19 3/8" deep installation hardware included edge styles available: <input type="checkbox"/> shaped wood front coped right/flat left</p>	3GV	36	19 3/8	1 1/4	45		575	670
	3GU	42	19 3/8	1 1/4	55		609	712
	3GT	48	19 3/8	1 1/4	65		645	753
	3GS	54	19 3/8	1 1/4	75		682	795
	3GR	60	19 3/8	1 1/4	85		717	833
	3GQ	66	19 3/8	1 1/4	90		751	878
	3GP	72	19 3/8	1 1/4	95		786	916

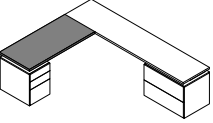
 <p>return top 24 3/8" deep installation hardware included edge styles available: <input type="checkbox"/> shaped wood front coped right/flat left</p>	3GM	36	24 3/8	1 1/4	55		602	701
	3GL	42	24 3/8	1 1/4	65		638	742
	3GK	48	24 3/8	1 1/4	75		671	782
	3GJ	54	24 3/8	1 1/4	85		709	826
	3GH	60	24 3/8	1 1/4	95		745	869
	3GG	66	24 3/8	1 1/4	100		779	908
	3GF	72	24 3/8	1 1/4	105		818	956

specification codes	series	sku	veneer	style	pull/hardware	finish	grommet placement
	<input type="checkbox"/> wood veneer		<input type="checkbox"/> grade 1 <input type="checkbox"/> cherry <input type="checkbox"/> walnut <input type="checkbox"/> maple <input type="checkbox"/> grade 2 <input type="checkbox"/> anigre	<input type="checkbox"/> shaped edge	<input type="checkbox"/> none	see page 7	<input type="checkbox"/> 3" left <input type="checkbox"/> 9" left <input type="checkbox"/> 3" right <input type="checkbox"/> 9" right <input type="checkbox"/> 3" both <input type="checkbox"/> 9" both <input type="checkbox"/> 3" center <input type="checkbox"/> 9" center <input type="checkbox"/> none 3" grommet/\$65 each 9" grommet specify separately see page 59
	<input type="checkbox"/>	<input type="checkbox"/>	<input type="checkbox"/>	<input type="checkbox"/>	<input type="checkbox"/>	<input type="checkbox"/>	<input type="checkbox"/>

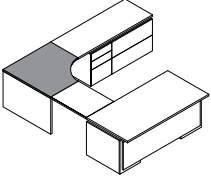
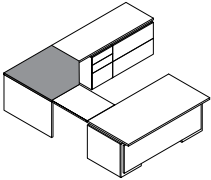
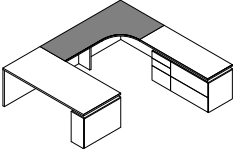
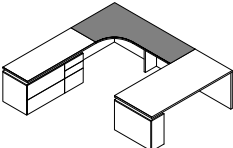
description	sku	w	d	h	weight	specifications	grade 1	grade 2
 <p>radius corner top</p> <p>use with 23$\frac{7}{8}$"d tops edge styles available:</p> <p><input type="checkbox"/> flat wood 4 sides <input type="checkbox"/> not available <input type="checkbox"/> shaped wood front</p>	FAN	42	42	1 $\frac{1}{4}$	115		\$ 1609	\$ 1845
 <p>straight corner top</p> <p>use with 23$\frac{7}{8}$"d tops edge styles available:</p> <p><input type="checkbox"/> flat wood 4 sides <input type="checkbox"/> metal 4 sides <input type="checkbox"/> shape wood front</p>	FEN	42	42	1 $\frac{1}{4}$	115		1248	1430
 <p>corner top extended left</p> <p>use with 23$\frac{7}{8}$"d tops edge styles available:</p> <p><input type="checkbox"/> flat wood 4 sides <input type="checkbox"/> not available <input type="checkbox"/> shaped wood front coped left/flat right</p>	2VP	65 $\frac{7}{8}$	42	1 $\frac{1}{4}$	150	use with 7B4 end panel, 84U wood fixed back panel, 7C2 mid-support panel	2116	2427
	2VQ	71 $\frac{7}{8}$	42	1 $\frac{1}{4}$	160	use with 7B4 end panel, 84T fixed back panel, 7C2 mid-support panel	2219	2546
 <p>corner top extended right</p> <p>use with 23$\frac{7}{8}$"d tops edge styles available:</p> <p><input type="checkbox"/> flat wood 4 sides <input type="checkbox"/> not available <input type="checkbox"/> shaped wood front coped right/flat left</p>	2VR	65 $\frac{7}{8}$	42	1 $\frac{1}{4}$	150	use with 7B4 end panel, 84U wood fixed back panel, 7C2 mid-support panel	2116	2427
	2VS	71 $\frac{7}{8}$	42	1 $\frac{1}{4}$	160	use with 7B4 end panel, 84T fixed back panel, 7C2 mid-support panel	2219	2546

specification codes	series	sku	veneer	style	pull/hardware	finish	grommet placement
	<input type="checkbox"/> wood veneer		grade 1 <input type="checkbox"/> cherry <input type="checkbox"/> walnut <input type="checkbox"/> maple grade 2 <input type="checkbox"/> anigre	<input type="checkbox"/> flat edge <input type="checkbox"/> metal edge <input type="checkbox"/> shaped edge	<input checked="" type="checkbox"/> none	see page 7	<input type="checkbox"/> 3" left <input type="checkbox"/> 9" left <input type="checkbox"/> 3" right <input type="checkbox"/> 9" right <input type="checkbox"/> 3" both <input type="checkbox"/> 9" both <input type="checkbox"/> 3" center <input type="checkbox"/> 9" center <input checked="" type="checkbox"/> none 3" grommet/\$65 each 9" grommet specify separately see page 59
	<input type="checkbox"/>	<input type="checkbox"/>	<input type="checkbox"/>	<input type="checkbox"/>	<input checked="" type="checkbox"/>	<input type="checkbox"/>	<input type="checkbox"/>

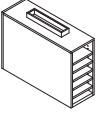
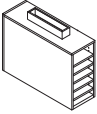
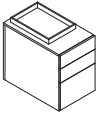
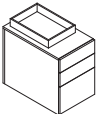
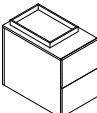
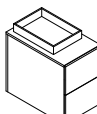
description	sku	w	d	h	weight	specifications	grade 1	grade 2
 <p>peninsula top pedestal 2 1/8" spacer open shelves finished back aligns peninsula top with workwall configurations 1 lock</p>	MUB	12	30	27 3/8	80		\$ 1361	\$ 1546
	MUA	12	36	27 3/8	90		1632	1854
 <p>peninsula top pedestal 3 3/8" spacer open shelves finished back use with overlapping peninsula top shown on page 25 1 lock</p>	MSB	12	30	28 5/8	80		1361	1559
	MSA	12	36	28 5/8	90		1632	1871
 <p>peninsula top pedestal 2 1/8" spacer BBF finished back aligns peninsula top with workwall configurations 1 lock</p>	MIV	15 7/8	19 5/8	27 3/8	95		1666	1908
	MIU	15 7/8	24 5/8	27 3/8	105		1686	1931
	MIT	15 7/8	29 5/8	27 3/8	115		1703	1952
	MIR	18	19 5/8	27 3/8	105		1666	1908
	MIX	18	24 5/8	27 3/8	115		1686	1931
	MIW	18	29 5/8	27 3/8	125		1703	1952
 <p>peninsula top pedestal 3 3/8" spacer BBF finished back use with overlapping peninsula top shown on page 25 1 lock</p>	MTV	15 7/8	19 5/8	28 5/8	95		1666	1908
	MTU	15 7/8	24 5/8	28 5/8	105		1686	1931
	MTT	15 7/8	29 5/8	28 5/8	115		1703	1952
	MTR	18	19 5/8	28 5/8	105		1666	1908
	MTX	18	24 5/8	28 5/8	115		1686	1931
	MTW	18	29 5/8	28 5/8	125		1703	1952
 <p>peninsula top pedestal 2 1/8" spacer FF finished back aligns peninsula top with workwall configuration 1 lock</p>	MGV	15 7/8	19 5/8	27 3/8	90		1499	1622
	MGU	15 7/8	24 5/8	27 3/8	100		1518	1740
	MGT	15 7/8	29 5/8	27 3/8	110		1537	1758
	MGR	18	19 5/8	27 3/8	100		1499	1717
	MGX	18	24 5/8	27 3/8	110		1518	1740
	MGW	18	29 5/8	27 3/8	120		1537	1758
 <p>peninsula top pedestal 3 3/8" spacer FF finished back use with overlapping peninsula top shown on page 25 1 lock</p>	MUV	15 7/8	19 5/8	28 5/8	90		1499	1622
	MUU	15 7/8	24 5/8	28 5/8	100		1518	1740
	MUT	15 7/8	29 5/8	28 5/8	110		1537	1758
	MUR	18	19 5/8	28 5/8	100		1499	1717
	MUX	18	24 5/8	28 5/8	110		1518	1740
	MUW	18	29 5/8	28 5/8	120		1537	1758

specification codes	series	sku	veneer	style	pull/hardware	finish	grommet
reference page 9 for product details	<input checked="" type="checkbox"/> wood veneer <input type="checkbox"/> paint		grade 1 <input checked="" type="checkbox"/> paint <input type="checkbox"/> cherry <input type="checkbox"/> 9 walnut <input type="checkbox"/> E maple grade 2 <input type="checkbox"/> Q anigre	<input checked="" type="checkbox"/> none	<input type="checkbox"/> 7 aluminum tab <input type="checkbox"/> 9 ecru leather <input checked="" type="checkbox"/> none	see page 7	<input checked="" type="checkbox"/> none
				<input checked="" type="checkbox"/>			<input checked="" type="checkbox"/>

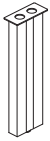
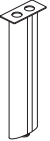
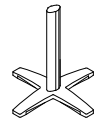
description	sku	w	d	h	weight	specifications	grade 1	grade 2
 <p>peninsula top pedestal leg</p> <p>rectangular aluminum leg wire management channel conceals wires specify series code C</p>	7QA	5½	9	27¾	20	aligns top with workwall	\$ 301	-
	7QB	5½	9	28¾	20	for overlapping tops	326	-
 <p>peninsula top pedestal leg</p> <p>oval aluminum leg wire management channel conceals wires specify series code C</p>	7RA	7½	2½	27¾	20	aligns top with workwall	301	-
 <p>S series pedestal leg</p> <p>oval aluminum leg sand cast aluminum base aligns top with workwall configurations channel conceals wires vinyl wire-way cover specify series code K</p>	7S2	27½	27½	27¾	20	use for 42"d and 48"d p-tops	672	-

specification codes	series	sku	veneer	style	pull/hardware	finish	grommet
reference page 9 for product details	<input type="checkbox"/> accessories <input type="checkbox"/> components		grade 1 <input checked="" type="checkbox"/> none	<input checked="" type="checkbox"/> none	<input type="checkbox"/> 4 aluminum		<input checked="" type="checkbox"/> none
			<input checked="" type="checkbox"/>	<input checked="" type="checkbox"/>	<input type="checkbox"/> 4	<input checked="" type="checkbox"/> <input checked="" type="checkbox"/> <input checked="" type="checkbox"/>	<input checked="" type="checkbox"/>

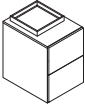
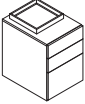
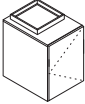
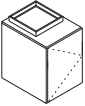
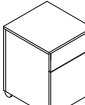
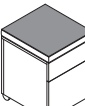
description	sku	w	d	h	weight	specifications	grade 1	grade 2
 <p>drawer pedestal FF specify top separately 2 1/2" spacer</p>	MHV	15 7/8	18 7/8	27 3/8	90	1 lock, use with open back credenza	\$ 1499	\$ 1622
	MHU	15 7/8	23 3/8	27 3/8	100	1 lock, use with open back credenza	1518	1740
	MHT	15 7/8	28 7/8	27 3/8	110	1 lock, use with open back credenza	1537	1758
	MHR	18	18 7/8	27 3/8	100	1 lock	1499	1622
	MHQ	18	23 3/8	27 3/8	110	1 lock	1518	1740
	MHP	18	28 7/8	27 3/8	120	1 lock	1555	1781
 <p>drawer pedestal BBF specify top separately 2 1/2" spacer</p>	MJV	15 7/8	18 7/8	27 3/8	95	1 lock, use with open back credenza	1572	1804
	MJU	15 7/8	23 3/8	27 3/8	105	1 lock, use with open back credenza	1592	1827
	MJT	15 7/8	28 7/8	27 3/8	115	1 lock, use with open back credenza	1622	1870
	MJR	18	18 7/8	27 3/8	105	1 lock	1572	1804
	MJQ	18	23 3/8	27 3/8	115	1 lock	1592	1827
	MJP	18	28 7/8	27 3/8	125	1 lock	1631	1870
 <p>door pedestal hinged left 1 adjustable shelf specify top separately 2 1/2" spacer</p>	MDV	15 7/8	18 7/8	27 3/8	90	1 lock, use with open back credenza	1174	1347
	MDU	15 7/8	23 3/8	27 3/8	100	1 lock, use with open back credenza	1213	1391
	MDR	18	18 7/8	27 3/8	95	1 lock	1213	1391
	MDQ	18	23 3/8	27 3/8	105	1 lock	1250	1431
 <p>door pedestal hinged right 1 adjustable shelf specify top separately 2 1/2" spacer</p>	MFV	15 7/8	18 7/8	27 3/8	90	1 lock, use with open back credenza	1174	1347
	MFU	15 7/8	23 3/8	27 3/8	100	1 lock, use with open back credenza	1213	1391
	MFR	18	18 7/8	27 3/8	90	1 lock	1213	1391
	MFQ	18	23 3/8	27 3/8	105	1 lock	1250	1431
 <p>mobile drawer pedestal BF five casters finished top and back</p>	L3R	18	19 5/8	22	80	1 lock	1739	1994
 <p>mobile drawer pedestal BF with seat cushion five casters finished back specify fabric separately list price does not include fabric see page 3 for instructions on tagging COM</p>	LN2	18	19 5/8	24 3/4	85	yardage required: 1 yard 1 lock	2113	2395

specification codes	series	sku	veneer	style	pull/hardware	finish	grommet
reference page 9 for product details	<input type="checkbox"/> wood veneer <input type="checkbox"/> paint		grade 1 <input checked="" type="checkbox"/> paint <input type="checkbox"/> cherry <input type="checkbox"/> walnut <input type="checkbox"/> maple grade 2 <input type="checkbox"/> anigre	<input checked="" type="checkbox"/> none	<input type="checkbox"/> aluminum tab <input type="checkbox"/> ecru leather <input checked="" type="checkbox"/> none	see page 7	<input checked="" type="checkbox"/> none
				<input checked="" type="checkbox"/>			<input checked="" type="checkbox"/>

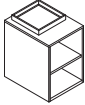
description	sku	w	d	h	weight	specifications	grade 1	grade 2
 <p>open pedestal 1 adjustable shelf specify top separately 2 1/8" spacer</p>	MBV	15 7/8	18 1/8	27 3/8	85	use with open back credenza	\$ 1092	\$ 1253
	MBU	15 7/8	23 1/8	27 3/8	95	use with open back credenza	1130	1297
	MBR	18	18 1/8	27 3/8	90		1130	1297
	MBQ	18	23 1/8	27 3/8	100		1167	1337

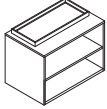
 <p>open lateral 1 adjustable shelf specify top separately 2 1/8" spacer</p>	NBM	30	18 1/8	27 3/8	130		1303	1494
	NBL	30	23 1/8	27 3/8	140		1343	1539
	NBK	36	18 1/8	27 3/8	140		1343	1539
	NBJ	36	23 1/8	27 3/8	150		1400	1583

specification codes	series	sku	veneer	style	pull/hardware	finish	grommet
reference page 9 for product details	<input type="checkbox"/> wood veneer <input type="checkbox"/> paint		grade 1 <input checked="" type="checkbox"/> paint <input type="checkbox"/> cherry <input type="checkbox"/> walnut <input type="checkbox"/> maple grade 2 <input type="checkbox"/> anigre	<input checked="" type="checkbox"/> none	<input checked="" type="checkbox"/> none	see page 7	<input checked="" type="checkbox"/> none
				<input checked="" type="checkbox"/>	<input checked="" type="checkbox"/>		<input checked="" type="checkbox"/>

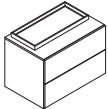
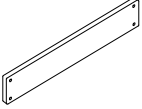
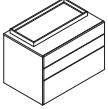
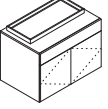
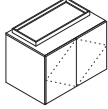
description	sku	w	d	h	weight	specifications	grade 1	grade 2
 <p>drawer lateral</p> <p>FF 2 1/8" spacer specify top separately if two or more are ganged and freestanding</p>	NHM	30	18 7/8	27 3/8	195	1 lock	\$ 1816	\$ 2081
	NHL	30	23 7/8	27 3/8	205	1 lock	1857	2128
	NHK	36	18 7/8	27 3/8	205	1 lock	1857	2128
	NHJ	36	23 7/8	27 3/8	215	1 lock	1899	2179
 <p>counterweight</p> <p>1/2" steel plate use with FF laterals when ganging and used as freestanding units specify series code C specify veneer code X specify pull/hardware code X</p>	P6Z	28 1/2	12	1/2	65		183	-
	P6Y	34 3/8	12	1/2	80		222	-
 <p>drawer lateral</p> <p>BBF 2 1/8" spacer specify top separately</p>	NJM	30	18 7/8	27 3/8	200	1 lock	1956	2242
	NJL	30	23 7/8	27 3/8	210	1 lock	1995	2288
	NJK	36	18 7/8	27 3/8	210	1 lock	1995	2288
	NJJ	36	23 7/8	27 3/8	220	1 lock	2035	2332
 <p>door/drawer lateral</p> <p>B2D 2 1/8" spacer 1 adjustable shelf specify top separately</p>	NFM	30	18 7/8	27 3/8	200	2 locks	1618	1854
	NFL	30	23 7/8	27 3/8	210	2 locks	1653	1894
	NFK	36	18 7/8	27 3/8	210	2 locks	1653	1894
	NFJ	36	23 7/8	27 3/8	220	2 locks	1688	1934
 <p>door lateral</p> <p>2D 2 1/8" spacer 1 adjustable shelf specify top separately</p>	NDM	30	18 7/8	27 3/8	195	1 lock	1580	1809
	NDL	30	23 7/8	27 3/8	205	1 lock	1618	1854
	NDK	36	18 7/8	27 3/8	205	1 lock	1618	1854
	NDJ	36	23 7/8	27 3/8	215	1 lock	1670	1915

specification codes	series	sku	veneer	style	pull/hardware	finish	grommet
reference page 9 for product details	<input type="checkbox"/> wood veneer <input type="checkbox"/> paint <input type="checkbox"/> accessories		grade 1 <input checked="" type="checkbox"/> paint/none <input type="checkbox"/> cherry <input type="checkbox"/> 9 walnut <input type="checkbox"/> E maple grade 2 <input type="checkbox"/> Q anigre	<input checked="" type="checkbox"/> none	<input type="checkbox"/> 7 aluminum <input type="checkbox"/> 9 ecru leather <input checked="" type="checkbox"/> none	see page 7	<input checked="" type="checkbox"/> none
				<input checked="" type="checkbox"/>			<input checked="" type="checkbox"/>

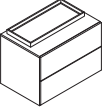
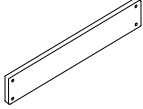
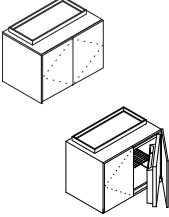
description	sku	w	d	h	weight	specifications	grade 1	grade 2
 <p>drawer lateral</p> <p>FF with anti-tilt use for freestanding units if two or more are ganged and freestanding a counterweight must be used specify top separately</p>	N9M	30	18 ⁷ / ₈	27 ³ / ₈	195	1 lock	\$ 2202	\$ 2524
	N9L	30	23 ⁷ / ₈	27 ³ / ₈	205	1 lock	2265	2596
	N9K	36	18 ⁷ / ₈	27 ³ / ₈	205	1 lock	2265	2596
	N9J	36	23 ⁷ / ₈	27 ³ / ₈	215	1 lock	2330	2669
 <p>counterweight</p> <p>1/2" steel plate use with FF laterals when ganging and used as freestanding units specify series code C specify veneer code X specify pull/hardware code X</p>	P6Z	28 1/2	12	1/2	65		183	-
	P6Y	34 3/8	12	1/2	80		222	-
 <p>refrigerator lateral</p> <p>vented back panel refrigerator not included uses a maximum 1.5 cubic feet size refrigerator interior dimensions for refrigerator: 20"w 22"d 23"h 2 adjustable shelves on left side</p>	NRL	30	23 ⁷ / ₈	27 ³ / ₈	200		2107	2416
	NRJ	36	23 ⁷ / ₈	27 ³ / ₈	210		2151	2468

specification codes	series	sku	veneer	style	pull/hardware	finish	grommet
reference page 9 for product details	<input type="checkbox"/> W wood veneer <input type="checkbox"/> P paint <input type="checkbox"/> C accessories		grade 1 <input checked="" type="checkbox"/> X paint/none <input type="checkbox"/> J cherry <input type="checkbox"/> 9 walnut <input type="checkbox"/> E maple grade 2 <input type="checkbox"/> Q anigre	<input checked="" type="checkbox"/> X none	<input type="checkbox"/> 7 aluminum tab <input type="checkbox"/> 9 ecru leather <input checked="" type="checkbox"/> X none	see page 7	<input checked="" type="checkbox"/> X none
				<input checked="" type="checkbox"/> X			<input checked="" type="checkbox"/> X

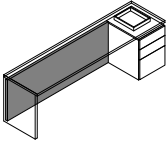
	description	sku	w	d	h	weight	specifications	grade 1	grade 2
	wood fixed back panel fits between pedestal and end panel	8DZ	16¾	1¼	25⅜	40		\$ 421	\$ 480
		8DY	22¾	1¼	25⅜	45		436	500
		8DW	28¾	1¼	25⅜	50		449	518
		8DV	34¾	1¼	25⅜	55		478	548
		8DU	40¾	1¼	25⅜	60		523	600
		8DT	46¾	1¼	25⅜	65		600	686
		8DS	52¾	1¼	25⅜	70	use with mid-support panel	676	790
		8DR	58¾	1¼	25⅜	75	use with mid-support panel	754	925
		8DQ	64¾	1¼	25⅜	80	use with mid-support panel	832	953
		8DP	70¾	1¼	25⅜	85	use with mid-support panel	908	1040
		8DN	76¾	1¼	25⅜	90	use with mid-support panel	986	1123
		8DM	82¾	1¼	25⅜	95	use with mid-support panel	1062	1215

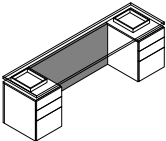
	wood fixed back panel fits between two pedestals	84Z	18	1¼	25⅜	40		421	480
		84Y	24	1¼	25⅜	45		436	500
		84W	30	1¼	25⅜	50		449	518
		84V	36	1¼	25⅜	55		478	548
		84U	42	1¼	25⅜	60		523	600
		84T	48	1¼	25⅜	65		600	686
		84S	54	1¼	25⅜	70	use with mid-support panel	676	790
		84R	60	1¼	25⅜	75	use with mid-support panel	754	925
		84Q	66	1¼	25⅜	80	use with mid-support panel	832	953
		84P	72	1¼	25⅜	85	use with mid-support panel	908	1040
		84N	78	1¼	25⅜	90	use with mid-support panel	986	1123
		84M	84	1¼	25⅜	95	use with mid-support panel	1062	1215

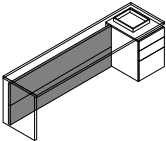
	wood access back panel fits between pedestal and end panel finished on inside only removeable panel	8EZ	16¾	4½	25⅜	45		697	799
		8EY	22¾	4½	25⅜	50		734	841
		8EW	28¾	4½	25⅜	55		759	869
		8EV	34¾	4½	25⅜	60		810	927
		8EU	40¾	4½	25⅜	65		847	970
		8ET	46¾	4½	25⅜	70		872	998

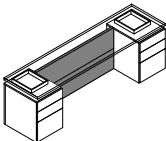
	wood access back panel fits between two pedestals finished on inside only removeable panel	85Z	18	4½	25⅜	45		697	799
		85Y	24	4½	25⅜	50		734	841
		85W	30	4½	25⅜	55		759	869
		85V	36	4½	25⅜	60		810	927
		85U	42	4½	25⅜	65		847	970
		85T	48	4½	25⅜	70		872	998

specification codes

reference page 10 for product details

series

- W wood veneer
- P paint

sku

--	--	--	--

veneer

- grade 1
- X paint
- J cherry
- 9 walnut
- E maple
- grade 2
- Q anigre

style

<input checked="" type="checkbox"/> none	
<input type="checkbox"/>	<input type="checkbox"/>

pull/hardware

<input checked="" type="checkbox"/> none	
<input type="checkbox"/>	<input type="checkbox"/>

finish

see page 7	

grommet

<input checked="" type="checkbox"/> none	
<input type="checkbox"/>	<input type="checkbox"/>

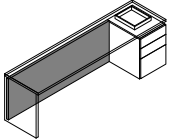
description	sku	w	d	h	weight	specifications	grade 1	grade 2
 <p>fabric access back panel fits between pedestal and end panel grey nylon mesh material aluminum top and base support rods removeable panel</p>	8GZ	16¾	4¼	25⅜	13		\$ 426	-
	8GY	22¾	4¼	25⅜	16		451	-
	8GW	28¾	4¼	25⅜	19		475	-
	8GV	34¾	4¼	25⅜	23		500	-
	8GU	40¾	4¼	25⅜	25		520	-
	8GT	46¾	4¼	25⅜	28		539	-

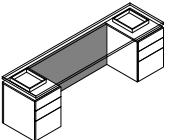
 <p>fabric access back panel fits between two pedestals grey nylon mesh material aluminum top and base support rods removeable panel</p>	8FZ	18	4¼	25⅜	13		426	-
	8FY	24	4¼	25⅜	16		451	-
	8FW	30	4¼	25⅜	19		475	-
	8FV	36	4¼	25⅜	23		500	-
	8FU	42	4¼	25⅜	25		520	-
	8FT	48	4¼	25⅜	28		539	-

specification codes	series	sku	veneer	style	pull/hardware	finish	grommet
reference page 10 for product details	<input type="checkbox"/> accessories		<input checked="" type="checkbox"/> grade 1 <input type="checkbox"/> none	<input checked="" type="checkbox"/> none	<input checked="" type="checkbox"/> none		<input checked="" type="checkbox"/> none
	<input type="checkbox"/>	<input type="checkbox"/>	<input type="checkbox"/>	<input type="checkbox"/>	<input type="checkbox"/>	<input type="checkbox"/> <input type="checkbox"/> <input type="checkbox"/>	<input type="checkbox"/>

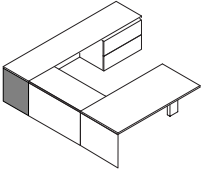
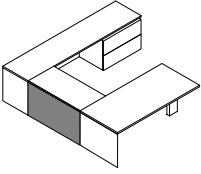
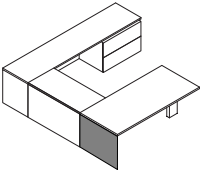
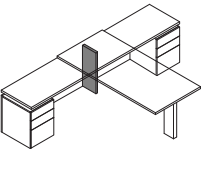
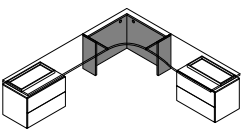
description	sku	w	d	h	weight	specifications	grade 1	grade 2
 <p>end panel support for void end of a credenza</p>	7B3	18 ⁷ / ₈	1 ¹ / ₄	27 ³ / ₈	30		\$ 421	\$ 494
	7B4	23 ⁷ / ₈	1 ¹ / ₄	27 ³ / ₈	40		447	524
	7B5	28 ⁷ / ₈	1 ¹ / ₄	27 ³ / ₈	50		499	585
 <p>bridge back panel</p>	81D	25	1 ¹ / ₄	27 ³ / ₈	45		504	590
	81E	31	1 ¹ / ₄	27 ³ / ₈	50		536	628
	81A	37	1 ¹ / ₄	27 ³ / ₈	55		567	664
	81B	43	1 ¹ / ₄	27 ³ / ₈	60		598	700
	81C	49	1 ¹ / ₄	27 ³ / ₈	65		634	744
 <p>end support panel use with peninsula tops</p>	7D7	30	1 ¹ / ₄	27 ³ / ₈	50		536	628
	7D8	36	1 ¹ / ₄	27 ³ / ₈	55		567	664
 <p>mid-support panel use with a credenza in void span longer than 48"</p>	7C2	12	1 ¹ / ₄	27 ³ / ₈	15		370	434
	7C3	18 ⁷ / ₈	1 ¹ / ₄	27 ³ / ₈	30		421	494
 <p>corner support panels assembly required wire access</p>	FKN	42	42	27 ³ / ₈	175		1276	1465

specification codes	series	sku	veneer	style	pull/hardware	finish	grommet
reference page 11 for product details	<input type="checkbox"/> wood veneer <input type="checkbox"/> paint		grade 1 <input type="checkbox"/> paint <input type="checkbox"/> cherry <input type="checkbox"/> walnut <input type="checkbox"/> maple grade 2 <input type="checkbox"/> anigre	<input checked="" type="checkbox"/> none	<input checked="" type="checkbox"/> none	see page 7	<input checked="" type="checkbox"/> none
				<input checked="" type="checkbox"/>	<input checked="" type="checkbox"/>		<input checked="" type="checkbox"/>

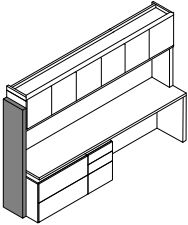
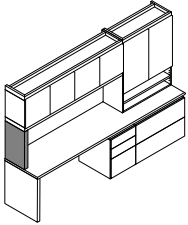
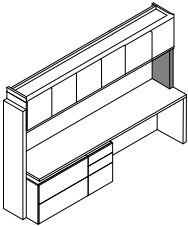
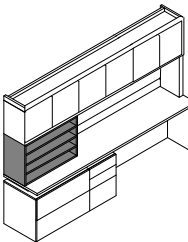
description	sku	w	d	h	weight	specifications	grade 1	grade 2
 <p>overhead end panel for left or right installation</p>	7F7	2¼	14¼	68¾	70		\$ 1326	\$ 1522
	7G7	2¼	14¼	78	80		1340	1535
 <p>overhead worksurface panel left panel</p>	7E8	2¼	14¼	24	25		826	948
 <p>overhead worksurface panel right panel</p>	7E7	2¼	14¼	24	25		826	948
 <p>overhead worksurface organizer 3 adjustable wood shelves</p>	Q22	15	14¼	24	95		904	1051
	Q23	18	14¼	24	105		918	1069
	Q2A	30	14¼	24	150		992	1136
	Q2B	36	14¼	24	160		1012	1158

specification codes	series	sku	veneer	style	pull/hardware	finish	grommet
reference page 11 for product details	<input type="checkbox"/> wood veneer <input type="checkbox"/> paint		grade 1 <input checked="" type="checkbox"/> paint <input type="checkbox"/> cherry <input type="checkbox"/> walnut <input type="checkbox"/> maple grade 1 <input type="checkbox"/> anigre	<input checked="" type="checkbox"/> none	<input checked="" type="checkbox"/> none	see page 7	<input checked="" type="checkbox"/> none
				<input checked="" type="checkbox"/>	<input checked="" type="checkbox"/>		<input checked="" type="checkbox"/>

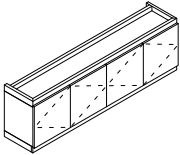
	description	sku	w	d	h	weight	specifications	grade 1	grade 2
	door overhead	O3Z	30	15	22¼	170	0 partitions 2 doors	\$ 1620	\$ 1785
		O3Y	36	15	22¼	190	0 partitions 2 doors	1779	1961
	wall mount	O3X	42	15	22¼	200	1 partition 3 doors	1936	2132
	single binder height	O3W	48	15	22¼	220	1 partition 3 doors	2330	2566
		O3V	54	15	22¼	240	1 partition 3 doors	2488	2742
		O3U	60	15	22¼	260	1 partition 4 doors	2644	2915
		O3T	66	15	22¼	280	1 partition 4 doors	2803	3088
		O3S	72	15	22¼	300	1 partition 4 doors	2960	3264
		O3R	78	15	22¼	320	1 partition 4 doors	3118	3438
		O3Q	84	15	22¼	340	2 partitions 6 doors	3513	3873
		O3P	90	15	22¼	360	2 partitions 6 doors	3669	4047
		O3O	96	15	22¼	380	2 partitions 6 doors	3829	4220
		O32	102	15	22¼	400	2 partitions 6 doors	3959	4406
		O3N	108	15	22¼	420	2 partitions 6 doors	4089	4566

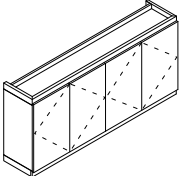
	door overhead	O3M	30	15	33⅝	320	0 partitions 2 doors	2187	2507
		O3L	36	15	33⅝	330	0 partitions 2 doors	2345	2688
	wall mount	O3K	42	15	33⅝	340	1 partitions 3 doors	2503	2870
	double binder height	O3J	48	15	33⅝	350	1 partition 3 doors	3024	3882
	1 adjustable shelf per section	O3I	54	15	33⅝	360	1 partition 3 doors	3544	4065
		O3H	60	15	33⅝	370	1 partition 4 doors	3700	4243
		O3G	66	15	33⅝	380	1 partition 4 doors	3858	4424
		O3F	72	15	33⅝	390	1 partition 4 doors	4016	4605
		O3E	78	15	33⅝	400	1 partition 4 doors	4175	4785
		O3D	84	15	33⅝	410	2 partitions 6 doors	4900	5618
		O3C	90	15	33⅝	420	2 partitions 6 doors	5059	5789
		O3B	96	15	33⅝	430	2 partitions 6 doors	5216	5980
		O33	102	15	33⅝	440	2 partitions 6 doors	5374	6147
		O3A	108	15	33⅝	450	2 partitions 6 doors	5532	6341

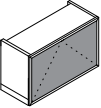
	flip-up accent overhead	O7Z	30	15⅞	22¼	170		2408	2754
		O7Y	36	15⅞	22¼	190		2643	3022
	back-painted white glass door with aluminum trim								
	3 adjustable half depth wood shelves								
	specify pull/hardware code 7								

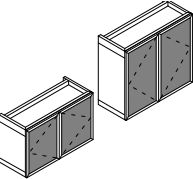
	glass door accent overhead	O5Z	30	15⅞	22¼	180		1996	2288
		O5Y	36	15⅞	22¼	200		2190	2511
	back-painted white glass door with aluminum trim	O5M	30	15⅞	33¼	320	1 adjustable shelf	2692	3086
	single and double binder heights	O5L	36	15⅞	33¼	330	1 adjustable shelf	2888	3312
	specify pull/hardware code 7								

specification codes	series	sku	veneer	style	pull/hardware	finish	grommet
reference page 12 for product details	<input type="checkbox"/> wood veneer <input type="checkbox"/> paint		grade 1 <input checked="" type="checkbox"/> paint <input type="checkbox"/> cherry <input type="checkbox"/> walnut <input type="checkbox"/> maple grade 2 <input type="checkbox"/> anigre	<input checked="" type="checkbox"/> none	<input type="checkbox"/> self pulls <input type="checkbox"/> aluminum tab <input type="checkbox"/> ecru leather	see page 7	<input checked="" type="checkbox"/> none
				<input checked="" type="checkbox"/>			<input checked="" type="checkbox"/>

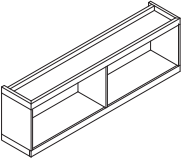
description	sku	w	d	h	weight	specifications	grade 1	grade 2
 <p>open overhead wall mount single binder height</p>	O2Z	30	14¼	22¼	160	0 partitions	\$ 988	\$ 1132
	O2Y	36	14¼	22¼	170	0 partitions	1146	1420
	O2X	42	14¼	22¼	180	1 partition	1304	1495
	O2W	48	14¼	22¼	190	1 partition	1460	1675
	O2V	54	14¼	22¼	200	1 partition	1619	1854
	O2U	60	14¼	22¼	210	1 partition	1778	2039
	O2T	66	14¼	22¼	220	1 partition	1935	2217
	O2S	72	14¼	22¼	230	1 partition	2094	2399
	O2R	78	14¼	22¼	240	1 partition	2252	2582
	O2Q	84	14¼	22¼	250	2 partitions	2410	2762
	O2P	90	14¼	22¼	260	2 partitions	2569	3086
	O2O	96	14¼	22¼	270	2 partitions	2723	3123
	O22	102	14¼	22¼	280	2 partitions	2881	3296
	O2N	108	14¼	22¼	290	2 partitions	3040	3482

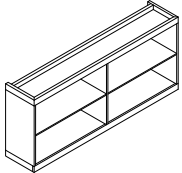
 <p>open overhead wall mount double binder height 1 adjustable shelf per section</p>	O2M	30	14¼	33⅝	260	0 partitions	1620	1857
	O2L	36	14¼	33⅝	270	0 partitions	1779	2040
	O2K	42	14¼	33⅝	280	1 partition	1936	2218
	O2J	48	14¼	33⅝	290	1 partition	2330	2669
	O2I	54	14¼	33⅝	300	1 partition	2448	2853
	O2H	60	14¼	33⅝	310	1 partition	2644	3032
	O2G	66	14¼	33⅝	320	1 partition	2803	3213
	O2F	72	14¼	33⅝	330	1 partition	2960	3295
	O2E	78	14¼	33⅝	340	1 partition	3118	3576
	O2D	84	14¼	33⅝	360	2 partitions	3513	4028
	O2C	90	14¼	33⅝	380	2 partitions	3669	4207
	O2B	96	14¼	33⅝	400	2 partitions	3829	4389
	O23	102	14¼	33⅝	420	2 partitions	3959	4529
	O2A	108	14¼	33⅝	440	2 partitions	4089	4750

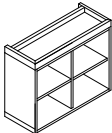
 <p>double height grid overhead</p>	O6Z	30	14¼	33⅝	260		1776	2036
	O6Y	36	14¼	33⅝	270		2612	2995

specification codes	series	sku	veneer	style	pull/hardware	finish	grommet
reference page 12 for product details	<input checked="" type="checkbox"/> wood veneer <input type="checkbox"/> paint		grade 1 <input checked="" type="checkbox"/> paint <input type="checkbox"/> cherry <input type="checkbox"/> walnut <input type="checkbox"/> maple grade 2 <input type="checkbox"/> anigre	<input checked="" type="checkbox"/> none	<input checked="" type="checkbox"/> none	see page 7	<input checked="" type="checkbox"/> none
				<input checked="" type="checkbox"/>	<input checked="" type="checkbox"/>		<input checked="" type="checkbox"/>

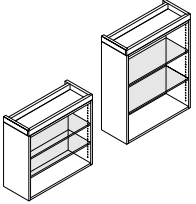
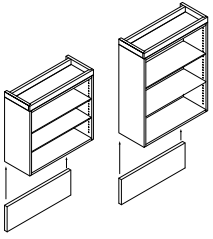
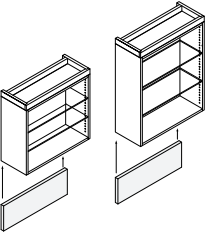
description	sku	w	d	h	weight	specifications	grade 1	grade 2
 <p>wall mount accent bookcase glass shelves two 10-watt halogen lights with switch</p>	U5Z	30	14¼	33¾	150	use with single binder height	\$ 3708	\$ 4252
	U5Y	36	14¼	33¾	175	use with single binder height	3909	4480
	U6Z	30	14¼	45¾	200	use with double binder height	4066	4663
	U6Y	36	14¼	45¾	215	use with double binder height	4781	5482
 <p>wood filler panel for wall mount accent bookcase aluminum trim use with wall mount accent bookcase specify pull/hardware code X</p>	U7Z	30	1¼	12¼	20		316	364
	U7Y	36	1¼	12¼	25		359	427
 <p>glass filler panel for wall mount accent bookcase aluminum trim back-painted white glass panel use with wall mount accent bookcase series code P specify veneer code X specify pull/hardware code X</p>	U8Z	30	1¼	12¼	20		441	-
	U8Y	36	1¼	12¼	25		497	-

specification codes	series	sku	veneer	style	pull/hardware	finish	grommet
reference page 12 for product details	<input checked="" type="checkbox"/> wood veneer <input type="checkbox"/> paint		grade 1 <input checked="" type="checkbox"/> paint <input type="checkbox"/> cherry <input type="checkbox"/> walnut <input type="checkbox"/> maple grade 2 <input type="checkbox"/> anigre	<input checked="" type="checkbox"/> none	<input checked="" type="checkbox"/> none	see page 7	<input checked="" type="checkbox"/> none
				<input checked="" type="checkbox"/>	<input checked="" type="checkbox"/>		<input checked="" type="checkbox"/>

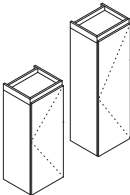
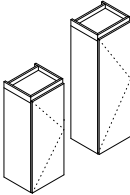
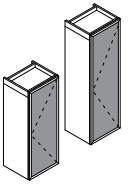
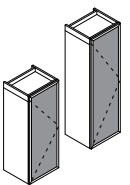
description	sku	w	d	h	weight	specifications	grade 1	grade 2
 <p>worksurface tower wood door hinged left</p>	Q14	15	15	46¼	100	1 fixed shelf, 2 adjustable shelves	\$ 1775	\$ 2036
	Q15	15	15	57½	110	1 fixed shelf, 3 adjustable shelves	1864	2137
	Q16	18	15	46¼	110	1 fixed shelf, 2 adjustable shelves	2198	2521
	Q17	18	15	57½	120	1 fixed shelf, 3 adjustable shelves	2312	2643
 <p>worksurface tower wood door hinged right</p>	QA4	15	15	46¼	100	1 fixed shelf, 2 adjustable shelves	1775	2036
	QA5	15	15	57½	110	1 fixed shelf, 3 adjustable shelves	1864	2137
	QA6	18	15	46¼	110	1 fixed shelf, 2 adjustable shelves	2198	2521
	QA7	18	15	57½	120	1 fixed shelf, 3 adjustable shelves	2312	2643
 <p>worksurface tower back-painted white glass door with aluminum trim hinged left specify pull/hardware code 7</p>	Q11	15	15½	46¼	100	1 fixed shelf, 2 adjustable shelves	2099	2406
	Q13	15	15½	57½	110	1 fixed shelf, 3 adjustable shelves	2267	2600
	Q12	18	15½	46¼	120	1 fixed shelf, 2 adjustable shelves	2565	2940
	Q18	18	15½	57½	130	1 fixed shelf, 3 adjustable shelves	2674	3184
 <p>worksurface tower back-painted white glass door with aluminum trim hinged right specify pull/hardware code 7</p>	QA1	15	15½	46¼	100	1 fixed shelf, 2 adjustable shelves	2099	2406
	QA3	15	15½	57½	110	1 fixed shelf, 3 adjustable shelves	2267	2600
	QA2	18	15½	46¼	110	1 fixed shelf, 2 adjustable shelves	2565	2940
	QA8	18	15½	57½	120	1 fixed shelf, 3 adjustable shelves	2570	3184

specification codes	series	sku	veener	style	pull/hardware	finish	grommet
reference page 12 for product details	<input type="checkbox"/> W wood veneer <input type="checkbox"/> P paint		grade 1 <input checked="" type="checkbox"/> X paint <input type="checkbox"/> J cherry <input type="checkbox"/> 9 walnut <input type="checkbox"/> E maple grade 2 <input type="checkbox"/> Q anigre	<input checked="" type="checkbox"/> X none	<input type="checkbox"/> 7 aluminum tab <input type="checkbox"/> 9 ecru leather	see page 7	<input checked="" type="checkbox"/> X none

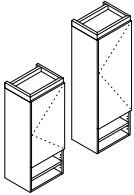
	description	sku	w	d	h	weight	specifications	grade 1	grade 2
	door/open worksurface tower hinged left wood door wood shelf below door	Q24	15	15	46¼	175	1 fixed, 2 adjustable shelves	\$ 1606	\$ 1839
		Q25	15	15	57½	185	1 fixed, 3 adjustable shelves	1690	1938
		Q26	18	15	46¼	195	1 fixed, 2 adjustable shelves	2029	2326
		Q27	18	15	57½	205	1 fixed, 3 adjustable shelves	2112	2422

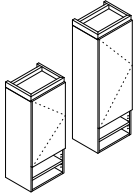
	door/open worksurface tower hinged right wood door wood shelf below door	QB4	15	15	46¼	175	1 fixed, 2 adjustable shelves	1606	1839
		QB5	15	15	57½	185	1 fixed, 3 adjustable shelves	1690	1938
		QB6	18	15	46¼	195	1 fixed, 2 adjustable shelves	2029	2326
		QB7	18	15	57½	205	1 fixed, 3 adjustable shelves	2112	2422

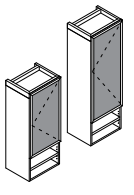
	door/open worksurface tower back-painted white glass door with aluminum trim wood shelf below door hinged left specify pull/hardware code 7	QJ4	15	15½	46¼	175	1 fixed, 2 adjustable shelves	2029	2356
		QJ5	15	15½	57½	185	1 fixed, 3 adjustable shelves	2211	2537
		QJ6	18	15½	46¼	195	1 fixed, 2 adjustable shelves	2541	2912
		QJ7	18	15½	57½	205	1 fixed, 3 adjustable shelves	2799	3122

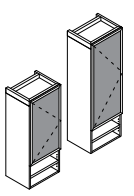
	door/open worksurface tower back-painted white glass door with aluminum trim wood shelf below door hinged right specify pull/hardware code 7	QK4	15	15½	46¼	175	1 fixed, 2 adjustable shelves	2029	2356
		QK5	15	15½	57½	185	1 fixed, 3 adjustable shelves	2211	2537
		QK6	18	15½	46¼	195	1 fixed, 2 adjustable shelves	2541	2912
		QK7	18	15½	57½	205	1 fixed, 3 adjustable shelves	2799	3122

specification codes	series	sku	veneer	style	pull/hardware	finish	grommet
reference page 12 for product details	<input type="checkbox"/> W wood veneer <input type="checkbox"/> P paint		<input checked="" type="checkbox"/> grade 1 <input type="checkbox"/> paint <input type="checkbox"/> cherry <input type="checkbox"/> 9 walnut <input type="checkbox"/> E maple <input type="checkbox"/> grade 2 <input type="checkbox"/> Q anigre	<input checked="" type="checkbox"/> none	<input type="checkbox"/> 7 aluminum tab <input type="checkbox"/> 9 ecru leather	see page 7	<input checked="" type="checkbox"/> none
				<input checked="" type="checkbox"/>			<input checked="" type="checkbox"/>

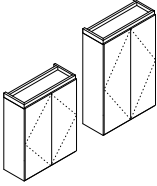
description	sku	w	d	h	weight	specifications	grade 1	grade 2
 <p>door worksurface tower double wood doors</p>	P3Z	30	15	46¼	275	1 fixed shelf, 2 adjustable shelves	\$ 3464	\$ 3978
	P3Y	36	15	46¼	285	1 fixed shelf, 2 adjustable shelves	3725	4271
	P3M	30	15	57½	280	1 fixed shelf, 3 adjustable shelves	4315	4947
	P3L	36	15	57½	290	1 fixed shelf, 3 adjustable shelves	4642	5321

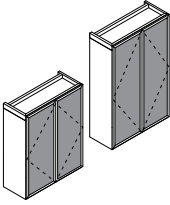
 <p>door worksurface tower double glass doors back-painted white glass doors with aluminum trim specify pull/hardware code 7</p>	P35	30	15½	46¼	275	1 fixed shelf, 2 adjustable shelves	4524	5187
	P36	36	15½	46¼	285	1 fixed shelf, 2 adjustable shelves	4768	5468
	P37	30	15½	57½	280	1 fixed shelf, 3 adjustable shelves	5496	6302
	P38	36	15½	57½	290	1 fixed shelf, 3 adjustable shelves	5621	6445

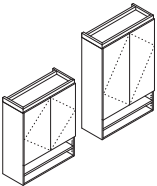
 <p>door/open worksurface tower double wood doors wood shelf below doors</p>	Q9Z	30	15	46¼	255	1 fixed shelf, 2 adjustable shelves	3363	3856
	Q9Y	36	15	46¼	265	1 fixed shelf, 2 adjustable shelves	3616	4145
	Q9M	30	15	57½	260	1 fixed shelf, 3 adjustable shelves	4188	4802
	Q9L	36	15	57½	270	1 fixed shelf, 3 adjustable shelves	4507	5176

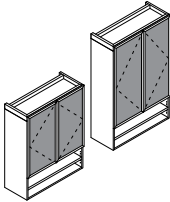
 <p>door/open worksurface tower back-painted white glass doors with aluminum trim wood shelf below doors specify pull/hardware code 7</p>	Q95	30	15½	46¼	255	1 fixed shelf, 2 adjustable shelves	4377	5018
	Q96	36	15½	46¼	265	1 fixed shelf, 2 adjustable shelves	4631	5310
	Q97	30	15½	57½	260	1 fixed shelf, 3 adjustable shelves	5360	6144
	Q98	36	15½	57½	270	1 fixed shelf, 3 adjustable shelves	5683	6514

specification codes	series	sku	veneer	style	pull/hardware	finish	grommet
reference page 12 for product details	<input type="checkbox"/> wood veneer <input type="checkbox"/> paint		grade 1 <input checked="" type="checkbox"/> paint <input type="checkbox"/> cherry <input type="checkbox"/> walnut <input type="checkbox"/> maple grade 2 <input type="checkbox"/> anigre	<input checked="" type="checkbox"/> none	<input type="checkbox"/> aluminum tab <input type="checkbox"/> ecru leather	see page 7	<input checked="" type="checkbox"/> none

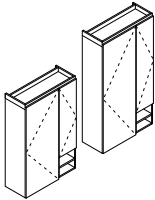
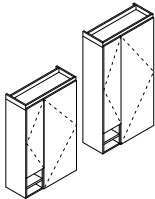
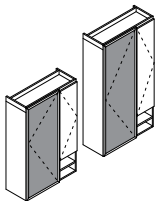
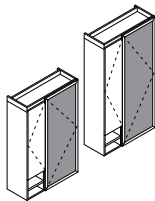
description	sku	w	d	h	weight	specifications	grade 1	grade 2
 <p>door/open worksurface tower</p> <p>asymmetrical double doors wood doors wood shelf on right below door</p>	QEY	36	15	46¼	260	2 fixed, 6 adjustable shelves	\$ 3435	\$ 3938
	QEL	36	15	57⅝	270	2 fixed, 6 adjustable shelves	4292	4919
 <p>door/open worksurface tower</p> <p>asymmetrical double doors wood doors wood shelf on left below door</p>	Q5Y	36	15	46¼	260	2 fixed, 6 adjustable shelves	3435	3938
	Q5L	36	15	57⅝	270	2 fixed, 6 adjustable shelves	4292	4919
 <p>door/open worksurface tower</p> <p>asymmetrical double doors back-painted white glass door on left with aluminum trim wood door on right with wood shelf below door specify pull/hardware code 7</p>	QH Y	36	15½	46¼	260	2 fixed, 6 adjustable shelves	5029	5767
	QH L	36	15½	57⅝	270	2 fixed, 6 adjustable shelves	6047	6842
 <p>door/open worksurface tower</p> <p>asymmetrical double doors back-painted white glass door on right with aluminum trim wood door on left with wood shelf below door specify pull/hardware code 7</p>	Q8 Y	36	15½	46¼	260	2 fixed, 6 adjustable shelves	5029	5767
	Q8 L	36	15½	57⅝	270	2 fixed, 6 adjustable shelves	6047	6842

specification codes

reference page 12
for product details

series

- W wood veneer
- P paint

sku

veneer

- grade 1
 - X paint
 - J cherry
 - 9 walnut
 - E maple
- grade 2
 - Q anigre

style

none

pull/hardware

- 7 aluminum tab
- 9 ecru leather

finish

see page 7

grommet

none

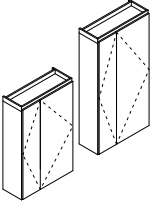
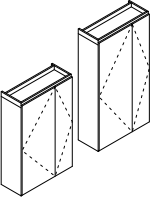
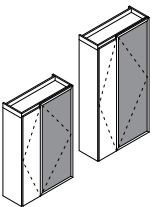
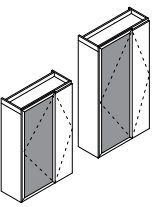
description	sku	w	d	h	weight	specifications	grade 1	grade 2
 <p>door worksurface tower asymmetrical double doors wood doors</p>	PXY	36	15	46¼	290	2 fixed, 6 adjustable shelves	\$ 3608	\$ 4134
	PXL	36	15	57½	300	2 fixed, 6 adjustable shelves	4507	5168
 <p>door worksurface tower asymmetrical double doors wood doors</p>	PZY	36	15	46¼	290	2 fixed, 6 adjustable shelves	3608	4134
	PZL	36	15	57½	300	2 fixed, 6 adjustable shelves	4507	5168
 <p>door worksurface tower asymmetrical double doors back-painted white glass door on right with aluminum trim specify pull/hardware code 7</p>	PWY	36	15½	46¼	290	2 fixed, 6 adjustable shelves	4272	4899
	PWL	36	15½	57½	300	2 fixed, 6 adjustable shelves	4990	6293
 <p>door worksurface tower asymmetrical double doors back-painted white glass door on left with aluminum trim specify pull/hardware code 7</p>	PYY	36	15½	46¼	290	2 fixed, 6 adjustable shelves	4272	4899
	PYL	36	15½	57½	300	2 fixed, 6 adjustable shelves	4990	6293

specification codes

reference page 12
for product details

series	sku	veneer	style	pull/hardware	finish	grommet
<input type="checkbox"/> wood veneer <input type="checkbox"/> paint		grade 1 <input checked="" type="checkbox"/> paint <input type="checkbox"/> cherry <input type="checkbox"/> walnut <input type="checkbox"/> maple grade 2 <input type="checkbox"/> anigre	<input checked="" type="checkbox"/> none	<input type="checkbox"/> aluminum tab <input type="checkbox"/> ecru leather	see page 7	<input checked="" type="checkbox"/> none
			<input checked="" type="checkbox"/>			<input checked="" type="checkbox"/>

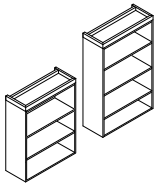
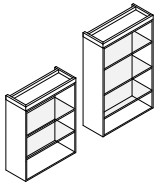
description	sku	w	d	h	weight	specifications	grade 1	grade 2
 <p>open worksurface tower 1" wood shelves</p>	Q6Z	30	14¼	46¼	245	2 adjustable shelves	\$ 2676	\$ 3065
	Q6Y	36	14¼	46¼	255	2 adjustable shelves	2857	3282
	Q6M	30	14¼	57⅝	250	3 adjustable shelves	3000	3441
	Q6L	36	14¼	57⅝	260	3 adjustable shelves	3655	4188
 <p>open worksurface tower glass shelves two 10-watt halogen lights with switch</p>	Q7Z	30	14¼	46¼	245	2 adjustable shelves	3710	4252
	Q7Y	36	14¼	46¼	255	2 adjustable shelves	3908	4480
	Q7M	30	14¼	57⅝	250	3 adjustable shelves	4067	4663
	Q7L	36	14¼	57⅝	260	3 adjustable shelves	4781	5482

specification codes	series	sku	veneer	style	pull/hardware	finish	grommet
reference page 12 for product details	<input type="checkbox"/> wood veneer <input type="checkbox"/> paint		grade 1 <input checked="" type="checkbox"/> paint <input type="checkbox"/> cherry <input type="checkbox"/> walnut <input type="checkbox"/> maple grade 2 <input type="checkbox"/> anigre	<input checked="" type="checkbox"/> none	<input checked="" type="checkbox"/> none	see page 7	<input checked="" type="checkbox"/> none
				<input checked="" type="checkbox"/>	<input checked="" type="checkbox"/>		<input checked="" type="checkbox"/>

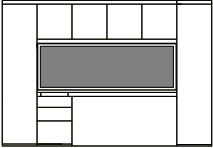
description	sku	w	d	h	weight	specifications	COM
 <p>tackboard aluminum frame specify fabric separately list price does not include fabric see page 3 for COM terms and conditions and instructions on tagging COM</p>	TZA	30	1½	24	20	30w overhead ydg. 1.0	\$ 229
	TYA	36	1½	24	25	36w overhead ydg. 1.2	243
	TXA	42	1½	24	30	42w overhead ydg. 1.4	271
	TWA	48	1½	24	35	48w overhead ydg. 1.6	284
	TVA	54	1½	24	40	54w overhead ydg. 1.9	314
	TUA	60	1½	24	45	60w overhead ydg. 1.9	340
	TTA	66	1½	24	50	66w overhead ydg. 2.1	356
	TSA	72	1½	24	55	72w overhead ydg. 2.3	382
	TRA	78	1½	24	60	78w overhead ydg. 2.4	409
	TQA	84	1½	24	65	84w overhead ydg. 2.6	439
	TPA	90	1½	24	70	90w overhead ydg. 2.7	467
	TOA	96	1½	24	75	96w overhead ydg. 2.9	506
	TMA	102	1½	24	80	102w overhead ydg. 3.1	521
	TNA	108	1½	24	85	108w overhead ydg. 3.3	536

 <p>tackboard aluminum frame use with one 2¼" w worksurface overhead support panel specify fabric separately list price does not include fabric see page 3 for COM terms and conditions and instructions on tagging COM</p>	TZB	27¾	1½	24	20	30w overhead ydg. 1.0	229
	TYB	33¾	1½	24	25	36w overhead ydg. 1.2	243
	TXB	39¾	1½	24	30	42w overhead ydg. 1.4	271
	TWB	45¾	1½	24	35	48w overhead ydg. 1.6	284
	TVB	51¾	1½	24	40	54w overhead ydg. 1.9	314
	TUB	57¾	1½	24	45	60w overhead ydg. 1.9	340
	TTB	63¾	1½	24	50	66w overhead ydg. 2.1	356
	TSB	69¾	1½	24	55	72w overhead ydg. 2.3	382
	TRB	75¾	1½	24	60	78w overhead ydg. 2.4	409
	TQB	81¾	1½	24	65	84w overhead ydg. 2.6	439
	TPB	87¾	1½	24	70	90w overhead ydg. 2.7	467
	TOB	93¾	1½	24	75	96w overhead ydg. 2.9	506
	TMB	99¾	1½	24	80	102w overhead ydg. 3.1	521
	TNB	105¾	1½	24	85	108w overhead ydg. 3.3	536

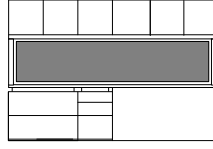
 <p>tackboard aluminum frame use with two 2¼" w worksurface overhead support panels specify fabric separately list price does not include fabric see page 3 for COM terms and conditions and instructions on tagging COM</p>	TZC	25½	1½	24	20	30w overhead ydg. 1.0	229
	TYC	31½	1½	24	25	36w overhead ydg. 1.2	243
	TXC	37½	1½	24	30	42w overhead ydg. 1.4	271
	TWC	43½	1½	24	35	48w overhead ydg. 1.6	284
	TVC	49½	1½	24	40	54w overhead ydg. 1.9	314
	TUC	55½	1½	24	45	60w overhead ydg. 1.9	340
	TTC	61½	1½	24	50	66w overhead ydg. 2.1	356
	TSC	67½	1½	24	55	72w overhead ydg. 2.3	382
	TRC	72½	1½	24	60	78w overhead ydg. 2.4	409
	TQC	79½	1½	24	65	84w overhead ydg. 2.6	439
	TPC	85½	1½	24	70	90w overhead ydg. 2.7	467
	TOC	91½	1½	24	80	96w overhead ydg. 2.9	506
	TMC	97½	1½	24	85	102w overhead ydg. 3.1	521
	TNC	103½	1½	24	90	108w overhead ydg. 3.3	536

specification codes	series	sku	veneer	style	pull/hardware	finish	grommet
reference page 13 for product details	<input checked="" type="checkbox"/> accessories		<input checked="" type="checkbox"/> COM	<input checked="" type="checkbox"/> none	<input checked="" type="checkbox"/> aluminum		<input checked="" type="checkbox"/> none
	<input type="checkbox"/>	<input type="checkbox"/>	<input type="checkbox"/>	<input type="checkbox"/>	<input type="checkbox"/>	<input type="checkbox"/>	<input type="checkbox"/>

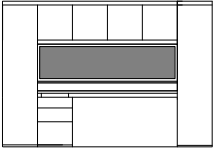
description	sku	w	d	h	weight	specifications	COM
 <p>tackboard for use with accessory rail</p> <p>aluminum frame specify accessory rail separately see page 61 specify fabric separately list price does not include fabric see page 3 for COM terms and conditions and instructions on tagging COM</p>	TZF	30	1½	19	20	30w overhead ydg. 1.0 uses accessory rail ARZ	\$ 229
	TYF	36	1½	19	25	36w overhead ydg. 1.2 uses accessory rail ARY	243
	TXF	42	1½	19	30	42w overhead ydg. 1.4 uses accessory rail ARX	271
	TWF	48	1½	19	35	48w overhead ydg. 1.6 uses accessory rail ARW	284
	TVF	54	1½	19	40	54w overhead ydg. 1.9 uses accessory rail ARV	314
	TUF	60	1½	19	45	60w overhead ydg. 1.9 uses accessory rail ARU	340
	TTF	66	1½	19	50	66w overhead ydg. 2.1 uses accessory rail ART	356
	TSF	72	1½	19	55	72w overhead ydg. 2.3 uses accessory rail ARS	382
	TRF	78	1½	19	60	78w overhead ydg. 2.4 uses accessory rail ARR	409
	TQF	84	1½	19	70	84w overhead ydg. 2.6 uses accessory rail ARQ	439
	TPF	90	1½	19	75	90w overhead ydg. 2.7 uses accessory rail ARP	467
	TOF	96	1½	19	80	96w overhead ydg. 2.9 uses accessory rail ARO	506
	TMF	102	1½	19	85	102w overhead ydg. 3.1 uses accessory rail ARM	521
	TNF	108	1½	19	90	108w overhead ydg. 3.3 uses accessory rail ARN	536

 <p>tackboard for use with accessory rail</p> <p>aluminum frame use with one 2¼" w worksurface overhead support panel specify accessory rail separately see page 61 specify fabric separately list price does not include fabric see page 3 for COM terms and conditions and instructions on tagging COM</p>	TZG	27¾	1½	19	20	30w overhead ydg. 1.0 uses accessory rail BRZ	229
	TYG	33¾	1½	19	25	36w overhead ydg. 1.2 uses accessory rail BRY	243
	TXG	39¾	1½	19	30	42w overhead ydg. 1.4 uses accessory rail BRX	271
	TWG	45¾	1½	19	35	48w overhead ydg. 1.6 uses accessory rail BRW	284
	TVG	51¾	1½	19	40	54w overhead ydg. 1.9 uses accessory rail BRV	314
	TUG	57¾	1½	19	45	60w overhead ydg. 1.9 uses accessory rail BRU	340
	TTG	63¾	1½	19	50	66w overhead ydg. 2.1 uses accessory rail BRT	356
	TSG	69¾	1½	19	55	72w overhead ydg. 2.3 uses accessory rail BRS	382
	TRG	75¾	1½	19	60	78w overhead ydg. 2.4 uses accessory rail BRR	409
	TQG	81¾	1½	19	65	84w overhead ydg. 2.6 uses accessory rail BRQ	439
	TPG	87¾	1½	19	70	90w overhead ydg. 2.7 uses accessory rail BRP	467
	TOG	93¾	1½	19	75	96w overhead ydg. 2.9 uses accessory rail BRO	506
	TMG	99¾	1½	19	80	102w overhead ydg. 3.1 uses accessory rail BRM	521
	TNG	105¾	1½	19	85	108w overhead ydg. 3.3 uses accessory rail BRN	536

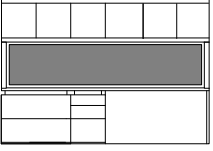
 <p>tackboard for use with accessory rail</p> <p>aluminum frame use with two 2¼" w worksurface overhead support panels specify accessory rail separately see page 61 specify fabric separately list price does not include fabric see page 3 for COM terms and conditions and instructions on tagging COM</p>	TZH	25½	1½	19	20	30w overhead ydg. 1.0 uses accessory rail CRZ	229
	TYH	31½	1½	19	25	36w overhead ydg. 1.2 uses accessory rail CRY	243
	TXH	37½	1½	19	30	42w overhead ydg. 1.4 uses accessory rail CRX	271
	TWH	43½	1½	19	35	48w overhead ydg. 1.6 uses accessory rail CRW	284
	TVH	49½	1½	19	40	54w overhead ydg. 1.9 uses accessory rail CRV	314
	TUH	55½	1½	19	45	60w overhead ydg. 1.9 uses accessory rail CRU	340
	TTH	61½	1½	19	50	66w overhead ydg. 2.1 uses accessory rail CRT	356
	TSH	67½	1½	19	55	72w overhead ydg. 2.3 uses accessory rail CRS	382
	TRH	73½	1½	19	60	78w overhead ydg. 2.4 uses accessory rail CRR	409
	TQH	79½	1½	19	65	84w overhead ydg. 2.6 uses accessory rail CRQ	439
	TPH	85½	1½	19	70	90w overhead ydg. 2.7 uses accessory rail CRP	467
	TOH	91½	1½	19	75	96w overhead ydg. 2.9 uses accessory rail CRO	506
	TMH	97½	1½	19	80	102w overhead ydg. 3.1 uses accessory rail CRM	521
	TNH	103½	1½	19	85	108w overhead ydg. 3.3 uses accessory rail CRN	536

specification codes	series	sku	veneer	style	pull/hardware	finish	grommet
reference page 13 for product details	<input checked="" type="checkbox"/> accessories		<input checked="" type="checkbox"/> COM	<input checked="" type="checkbox"/> none	<input checked="" type="checkbox"/> aluminum		<input checked="" type="checkbox"/> none
	<input type="checkbox"/>	<input type="checkbox"/>	<input type="checkbox"/>	<input type="checkbox"/>	<input type="checkbox"/>	<input type="checkbox"/>	<input type="checkbox"/>

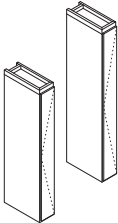
description	sku	w	d	h	weight	specifications	grade 1	grade 2
 <p>wardrobe vertical storage wood door hinged left fixed hat shelf coat rod</p>	SH8	9	18 $\frac{3}{8}$	74 $\frac{3}{8}$	125	1 fixed shelf	\$ 1662	\$ 1905
	SH7	9	23 $\frac{3}{8}$	74 $\frac{3}{8}$	150	1 fixed shelf	1724	1979
	SH6	9	18 $\frac{3}{8}$	86 $\frac{1}{4}$	175	1 fixed shelf	2044	2343
	SH5	9	23 $\frac{3}{8}$	86 $\frac{1}{4}$	200	1 fixed shelf	2108	2417

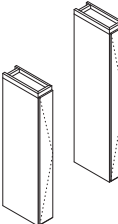
 <p>wardrobe vertical storage wood door hinged right fixed hat shelf coat rod</p>	SK8	9	18 $\frac{3}{8}$	74 $\frac{3}{8}$	125	1 fixed shelf	1662	1905
	SK7	9	23 $\frac{3}{8}$	74 $\frac{3}{8}$	150	1 fixed shelf	1724	1979
	SK6	9	18 $\frac{3}{8}$	86 $\frac{1}{4}$	175	1 fixed shelf	2044	2343
	SK5	9	23 $\frac{3}{8}$	86 $\frac{1}{4}$	200	1 fixed shelf	2108	2417

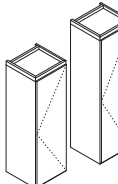
 <p>door vertical storage wood door hinged left coat rod</p>	S24	15	18 $\frac{3}{8}$	74 $\frac{3}{8}$	250	1 fixed, 3 adjustable shelves	1994	2285
	S23	15	23 $\frac{3}{8}$	74 $\frac{3}{8}$	275	1 fixed, 3 adjustable shelves	2070	2372
	S22	15	18 $\frac{3}{8}$	86 $\frac{1}{4}$	300	1 fixed, 3 adjustable shelves	2453	2810
	S21	15	23 $\frac{3}{8}$	86 $\frac{1}{4}$	325	1 fixed, 3 adjustable shelves	2529	2899
	S2Z	18	18 $\frac{3}{8}$	74 $\frac{3}{8}$	250	1 fixed, 3 adjustable shelves	2054	2354
	S2Y	18	23 $\frac{3}{8}$	74 $\frac{3}{8}$	275	1 fixed, 3 adjustable shelves	2132	2445
	S2W	18	18 $\frac{3}{8}$	86 $\frac{1}{4}$	300	1 fixed, 3 adjustable shelves	2525	2897
	S2V	18	23 $\frac{3}{8}$	86 $\frac{1}{4}$	325	1 fixed, 3 adjustable shelves	2605	2986

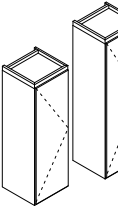
 <p>door vertical storage wood door hinged right coat rod</p>	SZ4	15	18 $\frac{3}{8}$	74 $\frac{3}{8}$	250	1 fixed, 3 adjustable shelves	1994	2285
	SZ3	15	23 $\frac{3}{8}$	74 $\frac{3}{8}$	275	1 fixed, 3 adjustable shelves	2070	2372
	SZ2	15	18 $\frac{3}{8}$	86 $\frac{1}{4}$	300	1 fixed, 3 adjustable shelves	2453	2810
	SZ1	15	23 $\frac{3}{8}$	86 $\frac{1}{4}$	325	1 fixed, 3 adjustable shelves	2529	2899
	SZZ	18	18 $\frac{3}{8}$	74 $\frac{3}{8}$	250	1 fixed, 3 adjustable shelves	2054	2354
	SZY	18	23 $\frac{3}{8}$	74 $\frac{3}{8}$	275	1 fixed, 3 adjustable shelves	2132	2445
	SZW	18	18 $\frac{3}{8}$	86 $\frac{1}{4}$	300	1 fixed, 3 adjustable shelves	2369	2464
	SZV	18	23 $\frac{3}{8}$	86 $\frac{1}{4}$	325	1 fixed, 3 adjustable shelves	2605	2986

specification codes	series	sku	veneer	style	pull/hardware	finish	grommet
reference page 12 for product details	<input checked="" type="checkbox"/> wood veneer		grade 1	<input checked="" type="checkbox"/> none	<input checked="" type="checkbox"/> aluminum tab	see page 7	<input checked="" type="checkbox"/> none
	<input type="checkbox"/> paint		<input checked="" type="checkbox"/> paint <input type="checkbox"/> cherry <input type="checkbox"/> walnut <input type="checkbox"/> maple		<input type="checkbox"/> ecru leather		
			grade 2 <input type="checkbox"/> anigre				

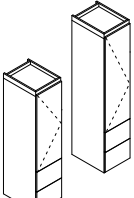
description	sku	w	d	h	weight	specifications	grade 1	grade 2
 <p>door/drawer vertical storage wood door hinged right FF</p>	SS4	15	18 $\frac{7}{8}$	74 $\frac{7}{8}$	275	1 lock 1 fixed, 2 adjustable shelves	\$ 2698	\$ 3094
	SS3	15	23 $\frac{7}{8}$	74 $\frac{7}{8}$	300	1 lock 1 fixed, 2 adjustable shelves	2776	3033
	SS2	15	18 $\frac{7}{8}$	86 $\frac{1}{4}$	325	1 lock 1 fixed, 3 adjustable shelves	3169	3627
	SS1	15	23 $\frac{7}{8}$	86 $\frac{1}{4}$	350	1 lock 1 fixed, 3 adjustable shelves	3307	3719
	SSZ	18	18 $\frac{7}{8}$	74 $\frac{7}{8}$	275	1 lock 1 fixed, 2 adjustable shelves	2915	3342
	SSY	18	23 $\frac{7}{8}$	74 $\frac{7}{8}$	300	1 lock 1 fixed, 2 adjustable shelves	3000	3438
	SSW	18	18 $\frac{7}{8}$	86 $\frac{1}{4}$	325	1 lock 1 fixed, 3 adjustable shelves	3422	3925
	SSV	18	23 $\frac{7}{8}$	86 $\frac{1}{4}$	350	1 lock 1 fixed, 3 adjustable shelves	3505	4018

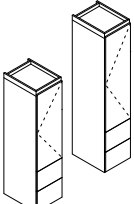
 <p>door/drawer vertical storage wood door hinged left FF</p>	S64	15	18 $\frac{7}{8}$	74 $\frac{7}{8}$	275	1 lock 1 fixed, 2 adjustable shelves	2698	3094
	S63	15	23 $\frac{7}{8}$	74 $\frac{7}{8}$	300	1 lock 1 fixed, 2 adjustable shelves	2776	3154
	S62	15	18 $\frac{7}{8}$	86 $\frac{1}{4}$	325	1 lock 1 fixed, 3 adjustable shelves	3169	3627
	S61	15	23 $\frac{7}{8}$	86 $\frac{1}{4}$	350	1 lock 1 fixed, 3 adjustable shelves	3307	3719
	S6Z	18	18 $\frac{7}{8}$	74 $\frac{7}{8}$	275	1 lock 1 fixed, 2 adjustable shelves	2915	3342
	S6Y	18	23 $\frac{7}{8}$	74 $\frac{7}{8}$	300	1 lock 1 fixed, 2 adjustable shelves	3000	3428
	S6W	18	18 $\frac{7}{8}$	86 $\frac{1}{4}$	325	1 lock 1 fixed, 3 adjustable shelves	3422	3925
	S6V	18	23 $\frac{7}{8}$	86 $\frac{1}{4}$	350	1 lock 1 fixed, 3 adjustable shelves	3505	4018

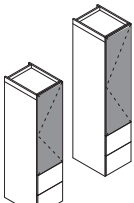
 <p>door/drawer vertical storage back-painted white glass door with aluminum trim hinged left FF specify pull/hardware code 7</p>	SP4	15	19	74 $\frac{7}{8}$	275	1 lock 1 fixed, 2 adjustable shelves	3328	3817
	SP3	15	24	74 $\frac{7}{8}$	300	1 lock 1 fixed, 2 adjustable shelves	3386	3876
	SP2	15	19	86 $\frac{1}{4}$	325	1 lock 1 fixed, 3 adjustable shelves	3937	4513
	SP1	15	24	86 $\frac{1}{4}$	350	1 lock 1 fixed, 3 adjustable shelves	4033	4623
	SPZ	18	19	74 $\frac{7}{8}$	275	1 lock 1 fixed, 2 adjustable shelves	3567	4089
	SPY	18	24	74 $\frac{7}{8}$	300	1 lock 1 fixed, 2 adjustable shelves	3659	4194
	SPW	18	19	86 $\frac{1}{4}$	325	1 lock 1 fixed, 3 adjustable shelves	4216	4833
	SPV	18	24	86 $\frac{1}{4}$	350	1 lock 1 fixed, 3 adjustable shelves	4307	4936

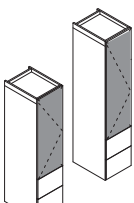
 <p>door/drawer vertical storage back-painted white glass door with aluminum trim hinged right FF specify pull/hardware code 7</p>	ST4	15	19	74 $\frac{7}{8}$	275	1 lock 1 fixed, 2 adjustable shelves	3328	3817
	ST3	15	24	74 $\frac{7}{8}$	300	1 lock 1 fixed, 2 adjustable shelves	3386	3876
	ST2	15	19	86 $\frac{1}{4}$	325	1 lock 1 fixed, 3 adjustable shelves	3937	4513
	ST1	15	24	86 $\frac{1}{4}$	350	1 lock 1 fixed, 3 adjustable shelves	4033	4623
	STZ	18	19	74 $\frac{7}{8}$	275	1 lock 1 fixed, 2 adjustable shelves	3567	4089
	STY	18	24	74 $\frac{7}{8}$	300	1 lock 1 fixed, 2 adjustable shelves	3659	4194
	STW	18	19	86 $\frac{1}{4}$	325	1 lock 1 fixed, 3 adjustable shelves	4216	4833
	STV	18	24	86 $\frac{1}{4}$	350	1 lock 1 fixed, 3 adjustable shelves	4307	4936

specification codes

reference page 12
for product details

series

W wood veneer
 P paint

sku

veneer

grade 1
 X paint
 J cherry
 9 walnut
 E maple
grade 2
 Q anigre

--

style

X none

X

pull/hardware

7 aluminum tab
 9 ecru leather

--

finish

see page 7

--

grommet

X none

X

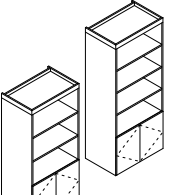
description	sku	w	d	h	weight	specifications	grade 1	grade 2
 <p>open/door vertical storage double wood doors wood shelves above doors</p>	S4U	30	18 ⁷ / ₈	74 ⁷ / ₈	330	1 lock 1 fixed, 3 adjustable shelves	\$ 3310	\$ 3795
	S4T	30	23 ⁷ / ₈	74 ⁷ / ₈	340	1 lock 1 fixed, 3 adjustable shelves	3429	3927
	S4S	30	18 ⁷ / ₈	86 ¹ / ₄	350	1 lock 1 fixed, 4 adjustable shelves	4156	4763
	S4R	30	23 ⁷ / ₈	86 ¹ / ₄	360	1 lock 1 fixed, 4 adjustable shelves	4271	4899
	S4Q	36	18 ⁷ / ₈	74 ⁷ / ₈	340	1 lock 1 fixed, 3 adjustable shelves	3555	4075
	S4P	36	23 ⁷ / ₈	74 ⁷ / ₈	350	1 lock 1 fixed, 3 adjustable shelves	3666	4203
	S4N	36	18 ⁷ / ₈	86 ¹ / ₄	360	1 lock 1 fixed, 4 adjustable shelves	4390	5033
	S4M	36	23 ⁷ / ₈	86 ¹ / ₄	370	1 lock 1 fixed, 4 adjustable shelves	4507	5168

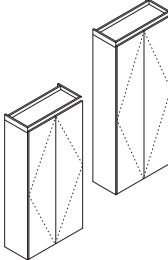
 <p>door vertical storage double wood doors depth aligns with overhead cabinets</p>	SAZ	30	15	74 ⁷ / ₈	370	1 fixed, 7 adjustable shelves	4070	4667
	SAY	30	15	86 ¹ / ₄	385	1 fixed, 9 adjustable shelves	4913	5619
	SAW	36	15	74 ⁷ / ₈	390	1 fixed, 7 adjustable shelves	4307	4936
	SAV	36	15	86 ¹ / ₄	405	1 fixed, 9 adjustable shelves	5148	5903

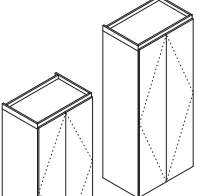
 <p>door vertical storage double wood doors coat rod</p>	S2U	30	18 ⁷ / ₈	74 ⁷ / ₈	420	1 fixed, 7 adjustable shelves	4070	4667
	S2T	30	23 ⁷ / ₈	74 ⁷ / ₈	430	1 fixed, 7 adjustable shelves	4188	4802
	S2S	30	18 ⁷ / ₈	86 ¹ / ₄	440	1 fixed, 9 adjustable shelves	4913	5632
	S2R	30	23 ⁷ / ₈	86 ¹ / ₄	450	1 fixed, 9 adjustable shelves	5032	5769
	S2Q	36	18 ⁷ / ₈	74 ⁷ / ₈	430	1 fixed, 7 adjustable shelves	4307	4936
	S2P	36	23 ⁷ / ₈	74 ⁷ / ₈	440	1 fixed, 7 adjustable shelves	4425	5074
	S2N	36	18 ⁷ / ₈	86 ¹ / ₄	450	1 fixed, 9 adjustable shelves	5148	5903
	S2M	36	23 ⁷ / ₈	86 ¹ / ₄	460	1 fixed, 9 adjustable shelves	5270	6041

specification codes	series	sku	veneer	style	pull/hardware	finish	grommet
reference page 12 for product details	<input checked="" type="checkbox"/> wood veneer <input type="checkbox"/> paint		grade 1 <input checked="" type="checkbox"/> paint <input type="checkbox"/> cherry <input type="checkbox"/> 9 walnut <input type="checkbox"/> E maple grade 2 <input type="checkbox"/> Q anigre	<input checked="" type="checkbox"/> none	<input type="checkbox"/> 7 aluminum tab <input type="checkbox"/> 9 ecru leather <input checked="" type="checkbox"/> none	see page 7	<input checked="" type="checkbox"/> none
				<input checked="" type="checkbox"/>			<input checked="" type="checkbox"/>

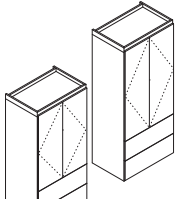
description	sku	w	d	h	weight	specifications	grade 1	grade 2
 <p>door/drawer vertical storage double wood doors 2 drawers</p>	SQU	30	18 $\frac{7}{8}$	74 $\frac{7}{8}$	380	1 lock 1 fixed, 2 adjustable shelves	\$ 4660	\$ 5343
	SQT	30	23 $\frac{7}{8}$	74 $\frac{7}{8}$	390	1 lock 1 fixed, 2 adjustable shelves	4946	5671
	SQS	30	18 $\frac{7}{8}$	86 $\frac{1}{4}$	400	1 lock 1 fixed, 3 adjustable shelves	5504	6309
	SQR	30	23 $\frac{7}{8}$	86 $\frac{1}{4}$	410	1 lock 1 fixed, 3 adjustable shelves	5791	6637
	SQQ	36	18 $\frac{7}{8}$	74 $\frac{7}{8}$	390	1 lock 1 fixed, 2 adjustable shelves	4898	5616
	SQP	36	23 $\frac{7}{8}$	74 $\frac{7}{8}$	400	1 lock 1 fixed, 2 adjustable shelves	5183	5942
	SQN	36	18 $\frac{7}{8}$	86 $\frac{1}{4}$	410	1 lock 1 fixed, 3 adjustable shelves	5740	6568
	SQM	36	23 $\frac{7}{8}$	86 $\frac{1}{4}$	420	1 lock 1 fixed, 3 adjustable shelves	6028	6892

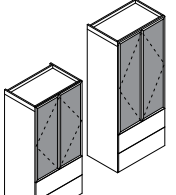
 <p>door/drawer vertical storage double back-painted white glass doors with aluminum trim 2 drawers specify pull/hardware code 7</p>	SRU	30	19	74 $\frac{7}{8}$	380	1 lock 1 fixed, 2 adjustable shelves	5757	6600
	SRT	30	24	74 $\frac{7}{8}$	390	1 lock 1 fixed, 2 adjustable shelves	6354	7258
	SRS	30	19	86 $\frac{1}{4}$	400	1 lock 1 fixed, 3 adjustable shelves	6732	7719
	SRR	30	24	86 $\frac{1}{4}$	410	1 lock 1 fixed, 3 adjustable shelves	6869	7875
	SRQ	36	19	74 $\frac{7}{8}$	390	1 lock 1 fixed, 2 adjustable shelves	6136	7034
	SRP	36	24	74 $\frac{7}{8}$	400	1 lock 1 fixed, 2 adjustable shelves	6701	7683
	SRN	36	19	86 $\frac{1}{4}$	410	1 lock 1 fixed, 3 adjustable shelves	7011	8039
	SRM	36	24	86 $\frac{1}{4}$	420	1 lock 1 fixed, 3 adjustable shelves	7109	8109

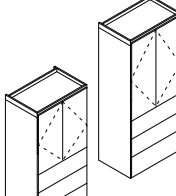
 <p>door/drawer vertical storage double wood doors 3 drawers</p>	S7U	30	18 $\frac{7}{8}$	74 $\frac{7}{8}$	390	1 lock 1 adjustable shelf	4660	5343
	S7T	30	23 $\frac{7}{8}$	74 $\frac{7}{8}$	400	1 lock 1 adjustable shelf	4946	5671
	S7S	30	18 $\frac{7}{8}$	86 $\frac{1}{4}$	410	1 lock 2 adjustable shelves	5504	6309
	S7R	30	23 $\frac{7}{8}$	86 $\frac{1}{4}$	420	1 lock 2 adjustable shelves	5791	6637
	S7Q	36	18 $\frac{7}{8}$	74 $\frac{7}{8}$	400	1 lock 1 adjustable shelf	4898	5616
	S7P	36	23 $\frac{7}{8}$	74 $\frac{7}{8}$	410	1 lock 1 adjustable shelf	5183	5942
	S7N	36	18 $\frac{7}{8}$	86 $\frac{1}{4}$	420	1 lock 2 adjustable shelves	5740	6568
	S7M	36	23 $\frac{7}{8}$	86 $\frac{1}{4}$	430	1 lock 2 adjustable shelves	6028	6892

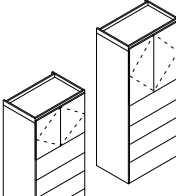
 <p>door/drawer vertical storage double wood doors 4 drawers</p>	S8U	30	18 $\frac{7}{8}$	74 $\frac{7}{8}$	400	1 lock	4746	5441
	S8T	30	23 $\frac{7}{8}$	74 $\frac{7}{8}$	410	1 lock	5023	5767
	S8S	30	18 $\frac{7}{8}$	86 $\frac{1}{4}$	420	1 lock 1 adjustable shelf	5589	6408
	S8R	30	23 $\frac{7}{8}$	86 $\frac{1}{4}$	430	1 lock 1 adjustable shelf	5875	6737
	S8Q	36	18 $\frac{7}{8}$	74 $\frac{7}{8}$	410	1 lock	4982	5711
	S8P	36	23 $\frac{7}{8}$	74 $\frac{7}{8}$	420	1 lock	5270	6041
	S8N	36	18 $\frac{7}{8}$	86 $\frac{1}{4}$	430	1 lock 1 adjustable shelf	5765	6596
	S8M	36	23 $\frac{7}{8}$	86 $\frac{1}{4}$	440	1 lock 1 adjustable shelf	6112	6993

specification codes

reference page 12
for product details

series	sku	veneer	style	pull/hardware	finish	grommet
<input type="checkbox"/> W wood veneer <input type="checkbox"/> P paint		grade 1 <input checked="" type="checkbox"/> X paint <input type="checkbox"/> J cherry <input type="checkbox"/> 9 walnut <input type="checkbox"/> E maple grade 2 <input type="checkbox"/> Q anigre	<input checked="" type="checkbox"/> X none	<input type="checkbox"/> 7 aluminum tab <input type="checkbox"/> 9 ecru leather	see page 7	<input checked="" type="checkbox"/> X none

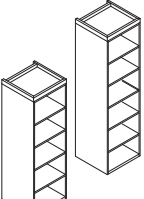
description	sku	w	d	h	weight	specifications	grade 1	grade 2
 <p>open vertical storage wood shelves</p>	S14	15	18 1/8	74 7/8	200	1 fixed, 3 adjustable shelves	\$ 2829	\$ 3243
	S13	15	23 1/8	74 7/8	225	1 fixed, 3 adjustable shelves	2912	3338
	S12	15	18 1/8	86 1/4	250	1 fixed, 4 adjustable shelves	3323	3809
	S11	15	23 1/8	86 1/4	275	1 fixed, 4 adjustable shelves	3403	3902
	S1Z	18	18 1/8	74 7/8	200	1 fixed, 3 adjustable shelves	2915	3342
	S1Y	18	23 1/8	74 7/8	225	1 fixed, 3 adjustable shelves	2998	3439
	S1W	18	18 1/8	86 1/4	250	1 fixed, 4 adjustable shelves	3422	3926
	S1V	18	23 1/8	86 1/4	275	1 fixed, 4 adjustable shelves	3505	4019

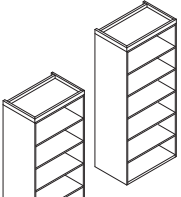
 <p>open vertical storage wood shelves</p>	S1U	30	18 1/8	74 7/8	375	1 fixed, 3 adjustable shelves	3472	3982
	S1T	30	23 1/8	74 7/8	385	1 fixed, 3 adjustable shelves	3788	4342
	S1S	30	18 1/8	86 1/4	395	1 fixed, 4 adjustable shelves	4263	4886
	S1R	30	23 1/8	86 1/4	405	1 fixed, 4 adjustable shelves	4498	5158
	S1Q	36	18 1/8	74 7/8	400	1 fixed, 3 adjustable shelves	3632	4162
	S1P	36	23 1/8	74 7/8	410	1 fixed, 3 adjustable shelves	3946	4526
	S1N	36	18 1/8	86 1/4	420	1 fixed, 4 adjustable shelves	4418	5068
	S1M	36	23 1/8	86 1/4	430	1 fixed, 4 adjustable shelves	4578	5247

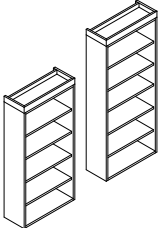
 <p>open vertical storage wood shelves depth aligns with overhead cabinets</p>	U6U	30	14 1/4	74 7/8	325	1 fixed, 3 adjustable shelves	2250	2586
	U6T	36	14 1/4	74 7/8	450	1 fixed, 3 adjustable shelves	2336	2679
	U6S	30	14 1/4	86 1/4	345	1 fixed, 4 adjustable shelves	2429	2783
	U6R	36	14 1/4	86 1/4	370	1 fixed, 4 adjustable shelves	2523	2894

specification codes

reference page 12 for product details

series

- W wood veneer
- P paint

sku

veneer

- grade 1**
- X paint
- J cherry
- 9 walnut
- E maple
- grade 2**
- Q anigre

style

<input checked="" type="checkbox"/> none
<input checked="" type="checkbox"/>

pull/hardware

<input checked="" type="checkbox"/> none
<input checked="" type="checkbox"/>

finish

see page 7

grommet

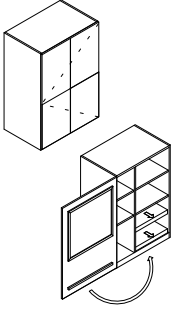
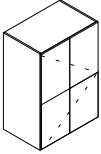
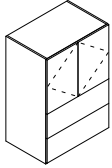
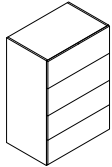

<input checked="" type="checkbox"/> none
<input checked="" type="checkbox"/>

description	sku	w	d	h	weight	specifications	grade 1	grade 2
 <p>door accent vertical storage cabinet</p> <p>single hinged door with reveals hinged left specify pull/hardware code 2 coat rod 3 adjustable shelves 2 pull out drawers for printer markerboard on inside of door designed to support overhead unit</p>	TBZ	30	18 $\frac{7}{8}$	52 $\frac{5}{8}$	315		\$ 4889	\$ 5578
	TBY	36	18 $\frac{7}{8}$	52 $\frac{5}{8}$	340		5150	5878
	TBU	30	23 $\frac{7}{8}$	52 $\frac{5}{8}$	325		5019	5729
	TBT	36	23 $\frac{7}{8}$	52 $\frac{5}{8}$	350		5280	6027
 <p>door accent vertical storage cabinet</p> <p>single hinged door with reveals hinged right specify pull/hardware code 2 coat rod 3 adjustable shelves 2 pull out drawers for printer markerboard on inside of door designed to support overhead unit</p>	TBS	30	18 $\frac{7}{8}$	52 $\frac{5}{8}$	315		4889	5578
	TBR	36	18 $\frac{7}{8}$	52 $\frac{5}{8}$	340		5150	5878
	TBW	30	23 $\frac{7}{8}$	52 $\frac{5}{8}$	325		5019	5729
	TBV	36	23 $\frac{7}{8}$	52 $\frac{5}{8}$	350		5280	6027
 <p>door/drawer accent vertical storage cabinet</p> <p>2 drawers 2 doors designed to support overhead unit</p>	TDZ	30	18 $\frac{7}{8}$	52 $\frac{5}{8}$	315	1 lock	4460	5049
	TDY	36	18 $\frac{7}{8}$	52 $\frac{5}{8}$	340	1 lock	4631	5310
	TDW	30	23 $\frac{7}{8}$	52 $\frac{5}{8}$	325	1 lock	4519	5181
	TDV	36	23 $\frac{7}{8}$	52 $\frac{5}{8}$	350	1 lock	4744	5440
 <p>drawer accent vertical storage cabinet</p> <p>4 drawers designed to support overhead unit</p>	TAZ	30	18 $\frac{7}{8}$	52 $\frac{5}{8}$	320	1 lock	4729	5419
	TAY	36	18 $\frac{7}{8}$	52 $\frac{5}{8}$	345	1 lock	4812	5516
	TAW	30	23 $\frac{7}{8}$	52 $\frac{5}{8}$	330	1 lock	4812	5516
	TAV	36	23 $\frac{7}{8}$	52 $\frac{5}{8}$	355	1 lock	4897	5615

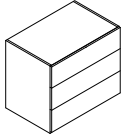
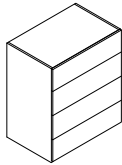
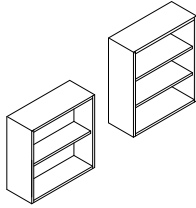

specification codes	series	sku	veneer	style	pull/hardware	finish	grommet
reference page 12 for product details	<input type="checkbox"/> wood veneer <input type="checkbox"/> paint		grade 1 <input checked="" type="checkbox"/> paint <input type="checkbox"/> cherry <input type="checkbox"/> walnut <input type="checkbox"/> maple grade 2 <input type="checkbox"/> anigre	<input checked="" type="checkbox"/> none	<input type="checkbox"/> self pull <input type="checkbox"/> aluminum tab <input type="checkbox"/> ecru leather	see page 7	<input checked="" type="checkbox"/> none
				<input checked="" type="checkbox"/>			<input checked="" type="checkbox"/>

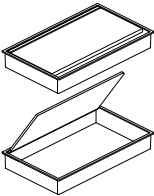
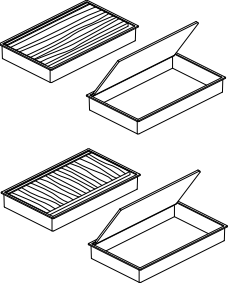
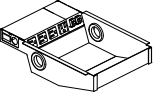
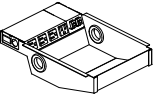
	description	sku	w	d	h	weight	specifications	grade 1	grade 2
	lateral file storage cabinet 3F anti-tilt finished top edge styles available: <input type="checkbox"/> flat wood 4 sides <input type="checkbox"/> shaped wood front if two or more are ganged and freestanding a counterweight must be used specify counterweight separately see page 65	T6Z	30	18 ⁷ / ₈	38 ⁷ / ₈	300	1 lock	\$ 4390	\$ 5034
		T6Y	36	18 ⁷ / ₈	38 ⁷ / ₈	325	1 lock	4476	5131
	lateral file storage cabinet 4F anti-tilt finished top edge styles available: <input type="checkbox"/> flat wood 4 sides <input type="checkbox"/> shaped wood front if two or more are ganged and freestanding a counterweight must be used specify counterweight separately see page 65	T9U	30	18 ⁷ / ₈	51 ¹ / ₈	320	1 lock	4729	5419
		T9T	36	18 ⁷ / ₈	51 ¹ / ₈	345	1 lock	4812	5516
	bookcase finished top 1" wood shelf edge styles available: <input type="checkbox"/> flat wood 4 sides <input type="checkbox"/> shaped wood front	U4Z	30	14 ¹ / ₄	34	150	1 adjustable shelf	1617	1853
		U4Y	36	14 ¹ / ₄	34	175	1 adjustable shelf	1692	1934
		U4W	30	14 ¹ / ₄	45 ³ / ₈	200	2 adjustable shelves	1951	2237
		U4V	36	14 ¹ / ₄	45 ³ / ₈	215	2 adjustable shelves	2027	2323

specification codes	series	sku	veneer	style	pull/hardware	finish	grommet
<input type="checkbox"/> W wood veneer <input type="checkbox"/> P paint			grade 1 <input checked="" type="checkbox"/> X paint <input type="checkbox"/> J cherry <input type="checkbox"/> Q walnut <input type="checkbox"/> E maple grade 2 <input type="checkbox"/> Q anigre	<input type="checkbox"/> F flat edge <input type="checkbox"/> S shaped edge	<input type="checkbox"/> Z aluminum tab <input type="checkbox"/> 9 ecru leather <input checked="" type="checkbox"/> X none	see page 7	<input checked="" type="checkbox"/> X none

description	sku	w	d	h	weight	specifications	grade 1	grade 2
 <p>communication grommet aluminum</p> <p>anodized aluminum specify location when ordering top specify series code K specify pull/hardware code 4</p>	VFA	9	5 1/4	1 1/4	5		\$ 229	-
 <p>communication grommet wood</p> <p>aluminum frame quarter cut veneer panel specify location when ordering top specify series code W specify veneer and finish codes specify pull/hardware code 4</p>	VFD	9	5 1/4	1 1/4	5	veneer grain long direction	410	426
	VFE	9	5 1/4	1 1/4	5	veneer grain short direction	410	426
 <p>power module</p> <p>9' cord 4 connection, 15 amp curcuit breaker 4 grounded outlets, 2 data communicators RJ45 jacks, rocker switch, wire storage use with VFA, VFD, or VFE communication grommet UL approved specify series code C specify pull/hardware code X</p>	VED	9	14 3/4	3 1/2	5		494	-
 <p>power module</p> <p>hard wired 4 connection, 15 amp curcuit breaker 4 grounded outlets, 2 data communicators RJ45 jacks, rocker switch, wire storage use with VFA, VFD, or VFE communication grommet UL/NY electrical code approved specify series code C specify pull/hardware code X</p>	VEE	9	14 3/4	3 1/2	5		506	-
 <p>communication grommet</p> <p>die cast zinc brushed aluminum fits 2 1/2" opening specify series code C specify veneer code X specify pull/hardware code 4</p>	GNC	3	3	7/8		specify with table top order	65	
	GMT	3	3	7/8		field installed	50	

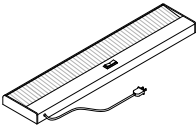
specification codes	series	sku	veneer	style	pull/hardware	finish	grommet
reference page 14 for product details	<input type="checkbox"/> W wood veneer <input type="checkbox"/> C accessories <input type="checkbox"/> K components		<input checked="" type="checkbox"/> X none <input type="checkbox"/> J cherry <input type="checkbox"/> 9 walnut <input type="checkbox"/> E maple grade 2 <input type="checkbox"/> Q anigre	<input checked="" type="checkbox"/> X none	<input type="checkbox"/> 4 aluminum <input checked="" type="checkbox"/> X none	see page 7	<input checked="" type="checkbox"/> X none
				<input checked="" type="checkbox"/> X			<input checked="" type="checkbox"/> X

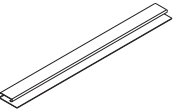
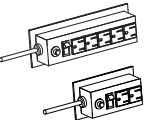
	description	sku	w	d	h	weight	specifications	grade 1	grade 2
	task light	L1Z	24	6 7/8	1 1/2	5		\$ 228	—
		L1W	36	6 7/8	1 1/2	10		251	—
		L1U	60	6 7/8	1 1/2	15		269	—
	black baked enamel								
	9' long cord								
	90° angle plug								
	rocker switch	L1R	24	6 7/8	1 1/2	5	chicago approved fixed plug	263	—
	T8/265mna/3500k	L1S	36	6 7/8	1 1/2	10	chicago approved fixed plug	289	—
	tri-phosphor lamp	L1T	60	6 7/8	1 1/2	15	chicago approved fixed plug	315	—
	thermal protection class p rapid start ballast UL/CSA Approved	L1N	24	6 7/8	1 1/2	5	new york approved mounting clip	263	—
	L1P	36	6 7/8	1 1/2	10	new york approved mounting clip	289	—	
	L1Q	60	6 7/8	1 1/2	15	new york approved mounting clip	315	—	
	wire management clip	E5E	1	1	7/8	5		37	-
4 clips per package mounting screws included black finish									
	wire manager	E5Z	24	1	2 3/8	10		36	-
		E5Y	30	1	2 3/8	12		42	-
	black pvc	E5W	36	1	2 3/8	15		55	-
	mounting screws included								
	power harness with cord	VEP	9 1/2	2 3/4	1 3/4	10	5 grounded outlets	118	-
		VEA	4 3/4	2 3/4	1 3/4	5	2 grounded outlets	77	-
	10' cord with ground plug 15 amp circuit breaker black plastic surface mount rocker switch UL/CSA approved rated for 120 volt 60 Hz at 15 amps pull/hardware code X								

specification codes	series	sku	veneer	style	pull/hardware	finish	grommet
reference page 14 for product details	<input checked="" type="checkbox"/> accessories		<input checked="" type="checkbox"/> grade 1 <input checked="" type="checkbox"/> none	<input checked="" type="checkbox"/> none	<input checked="" type="checkbox"/> none		<input checked="" type="checkbox"/> none
			<input checked="" type="checkbox"/>	<input checked="" type="checkbox"/>	<input checked="" type="checkbox"/>	<input checked="" type="checkbox"/> <input checked="" type="checkbox"/> <input checked="" type="checkbox"/>	<input checked="" type="checkbox"/>

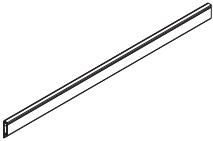
description	sku	w	d	h	weight	specifications	grade 1	grade 2
 <p>accessory rail extruded aluminum rail attaches to worksurface can be used with tackboards shown on page 51 mounting hardware included</p>	ARZ	30	1½	5	5		\$ 283	-
	ARY	36	1½	5	5		295	-
	ARX	42	1½	5	6		309	-
	ARW	48	1½	5	6		320	-
	ARV	54	1½	5	7		334	-
	ARU	60	1½	5	7		345	-
	ART	66	1½	5	8		358	-
	ARS	72	1½	5	8		369	-
	ARR	78	1½	5	9		383	-
	ARQ	84	1½	5	9		395	-
	ARP	90	1½	5	10		408	-
	ARO	96	1½	5	10		420	-
	ARM	102	1½	5	11		433	-
	ARN	108	1½	5	11		445	-

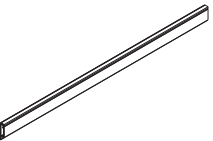
 <p>accessory rail extruded aluminum rail attaches to worksurface can be used with tackboard and one 2¼" w support panel shown on page 51 mounting hardware included</p>	BRZ	27¾	1½	5	5		283	-
	BRY	33¾	1½	5	5		295	-
	BRX	39¾	1½	5	6		309	-
	BRW	45¾	1½	5	6		320	-
	BRV	51¾	1½	5	7		334	-
	BRU	57¾	1½	5	7		345	-
	BRT	63¾	1½	5	8		358	-
	BRS	69¾	1½	5	8		369	-
	BRR	75¾	1½	5	9		383	-
	BRQ	81¾	1½	5	9		395	-
	BRP	87¾	1½	5	10		408	-
	BRO	93¾	1½	5	10		420	-
	BRM	99¾	1½	5	11		433	-
	BRN	105¾	1½	5	11		445	-

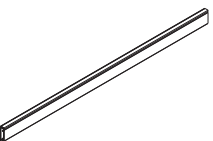
 <p>accessory rail extruded aluminum rail attaches to worksurface can be used with tackboard and two 2¼" w support panels shown on page 51 mounting hardware included</p>	CRZ	25½	1½	5	5		283	-
	CRY	31½	1½	5	5		295	-
	CRX	37½	1½	5	6		309	-
	CRW	43½	1½	5	6		320	-
	CRV	49½	1½	5	7		334	-
	CRU	55½	1½	5	7		345	-
	CRT	61½	1½	5	8		358	-
	CRS	67½	1½	5	8		369	-
	CRR	73½	1½	5	9		383	-
	CRQ	79½	1½	5	9		395	-
	CRP	85½	1½	5	10		408	-
	CRO	91½	1½	5	10		420	-
	CRM	97½	1½	5	11		433	-
	CRN	103½	1½	5	11		445	-

specification codes	series	sku	veneer	style	pull/hardware	finish	grommet
reference page 13 for product details	<input type="checkbox"/> accessories		grade 1 <input checked="" type="checkbox"/> none	<input checked="" type="checkbox"/> none	<input checked="" type="checkbox"/> aluminum		<input checked="" type="checkbox"/> none
	<input type="checkbox"/>	<input type="checkbox"/>	<input checked="" type="checkbox"/>	<input checked="" type="checkbox"/>	<input checked="" type="checkbox"/>	<input checked="" type="checkbox"/> <input checked="" type="checkbox"/> <input checked="" type="checkbox"/>	<input checked="" type="checkbox"/>

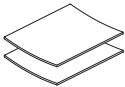
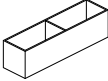
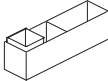
description	sku	w	d	h	weight	specifications	grade 1	grade 2
 <p>paper tray</p> <p>2 white acrylic shelves 1 silver mounting bracket series code C finish code XXX</p>	AAF	13	9½	3¾	5		\$ 276	-
	AAK	16	9½	3¾	5		301	-
 <p>wood storage box</p> <p>solid maple box specify wood or paint finish mounting bracket included series code W or P veneer code E</p>	AAH	15	3¾	3¾	10	box only	420	-
	AAJ	15	3¾	3¾	15	box with ceramic pencil holder	451	-
 <p>wood storage box with pencil holder</p> <p>solid maple box white ceramic pencil holder specify wood or paint finish mounting bracket included series code W or P</p>	AAJ	15	3¾	3¾	15	box with ceramic pencil holder	451	-



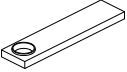
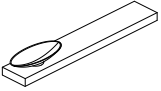
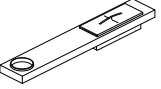
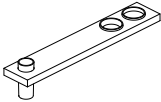
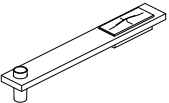
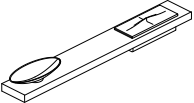
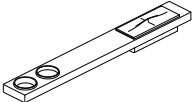
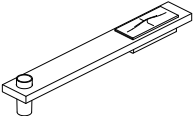

specification codes	series	sku	veneer	style	pull/hardware	finish	grommet
reference page 13 for product details	<input type="checkbox"/> W wood veneer <input type="checkbox"/> P paint <input type="checkbox"/> C accessories		grade 1 <input checked="" type="checkbox"/> X paint <input type="checkbox"/> E maple	<input checked="" type="checkbox"/> X none	<input checked="" type="checkbox"/> X none	see page 7	<input checked="" type="checkbox"/> X none
				<input checked="" type="checkbox"/> X	<input checked="" type="checkbox"/> X		<input checked="" type="checkbox"/> X

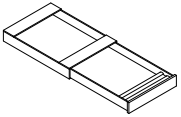
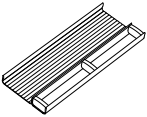
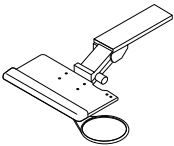
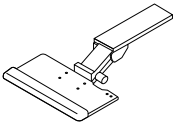
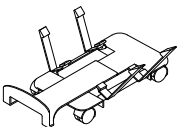
	description	sku	w	d	h	weight	specifications	grade 1	grade 2
	wood accessory shelf solid maple shelf includes white ceramic accessory shown	ZRA	18	14	1¼	15		\$ 451	-
	wood accessory shelf solid maple shelf includes white ceramic accessory shown	ZRB	24	4	1¼	20		500	-
	wood accessory shelf solid maple shelf includes white ceramic accessories shown	ZRC	24	4	1¼	20		551	-
	wood accessory shelf solid maple shelf includes white ceramic accessories shown	ZRD	24	4	1¼	20		539	-
	wood accessory shelf solid maple shelf includes white ceramic accessories shown	ZRE	24	4	1¼	20		551	-
	wood accessory shelf solid maple shelf includes white ceramic accessories shown	ZRF	30	4	1¼	25		601	-
	wood accessory shelf solid maple shelf includes white ceramic accessories shown	ZRG	30	4	1¼	25		589	-
	wood accessory shelf solid maple shelf includes white ceramic accessories shown	ZRH	30	4	1¼	25		551	-

specification codes	series	sku	veneer	style	pull/hardware	finish	grommet
reference page 13 for product details	<input type="checkbox"/> wood veneer <input type="checkbox"/> paint		<input checked="" type="checkbox"/> grade 1 <input type="checkbox"/> paint <input type="checkbox"/> maple	<input checked="" type="checkbox"/> none	<input checked="" type="checkbox"/> none	see page 7	<input checked="" type="checkbox"/> none
				<input checked="" type="checkbox"/>	<input checked="" type="checkbox"/>		<input checked="" type="checkbox"/>

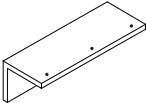
description	sku	w	d	h	weight	specifications	grade 1	grade 2
 <p>pencil drawer</p> <p>wood drawer suspension metal slide mounting can be mounted under any top veneer code E specify wood finish</p>	P7Z	25 $\frac{7}{8}$	17	2	20		\$ 585	-
 <p>drawer organizer tray</p> <p>extruded aluminum 4 dividers veneer code X</p>	P3V	12 $\frac{1}{4}$	6	1 $\frac{3}{8}$	5		77	-
	P3U	14 $\frac{3}{8}$	6	1 $\frac{3}{8}$	5		77	-
 <p>key board tray w/mouse pad</p> <p>humanscale® black powdercoat knob free height and tilt gel palm rest veneer code X</p>	KEX					17 $\frac{3}{4}$ " track	428	-
	KAX					21 $\frac{3}{8}$ " track	428	-
 <p>key board tray w/o mouse pad</p> <p>humanscale® black powdercoat knob free height and tilt gel palm rest veneer code X</p>	KDX					17 $\frac{3}{4}$ " track	375	-
	KBX					21 $\frac{3}{8}$ " track	375	-
 <p>mobile cpu cart</p> <p>humanscale® black powdercoat adjusts to support a 9" cpu casters veneer code X</p>	KCX	8 $\frac{3}{4}$	15	16 $\frac{1}{4}$			263	-

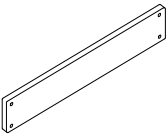
specification codes	series	sku	veneer	style	pull/hardware	finish	grommet
	<input checked="" type="checkbox"/> accessories		<input checked="" type="checkbox"/> grade 1 <input checked="" type="checkbox"/> none <input type="checkbox"/> E maple	<input checked="" type="checkbox"/> none	<input checked="" type="checkbox"/> none	see page 7	<input checked="" type="checkbox"/> none
	<input type="checkbox"/> C	<input type="checkbox"/> <input type="checkbox"/> <input type="checkbox"/> <input type="checkbox"/>	<input type="checkbox"/>	<input checked="" type="checkbox"/> X	<input checked="" type="checkbox"/> X	<input type="checkbox"/> <input type="checkbox"/> <input type="checkbox"/>	<input checked="" type="checkbox"/> X

description	sku	w	d	h	weight	specifications	grade 1	grade 2
 <p>wall mount bracket</p>	K8A	18	3	2	6		\$ 83	-
	K8B	24	3	2	9		89	-
	K8C	30	3	2	11		95	-
 <p>flat bracket</p>	K9D	14	1/8	3	5		59	-
	K9W	26	1/8	3	10		77	-
 <p>counterweight</p> <p>1/2" steel plate use with FF laterals when ganging for field installation mounts externally to the back of cases with standard backs</p>	P6Z	28 1/2	1/2	12	65		183	-
	P6Y	34 3/8	1/2	12	80		222	-
 <p>worksurface cantilever bracket</p> <p>interchangeable mount</p>	P58	2	17 3/4	11 1/8	8		166	-

specification codes	series	sku	veneer	style	pull/hardware	finish	grommet
	<input type="checkbox"/> accessories		<input type="checkbox"/> grade 1 <input type="checkbox"/> none	<input checked="" type="checkbox"/> none	<input checked="" type="checkbox"/> none		<input checked="" type="checkbox"/> none
	<input type="checkbox"/>	<input type="checkbox"/>	<input checked="" type="checkbox"/>	<input checked="" type="checkbox"/>	<input checked="" type="checkbox"/>	<input checked="" type="checkbox"/> <input checked="" type="checkbox"/> <input checked="" type="checkbox"/>	<input checked="" type="checkbox"/>