

itinerary  
price list

april 2010

### Itinerary Ordering Information

Each item has a multi-character ordering code comprised of letters and numbers representing design selections found in the specification code grid. The grid is located at the bottom of each page and lists the

selections particular to the items shown on that page. The grid immediately below shows all design selections possible for the Itinerary tables collection. Explanations of each design selection follows.

specification codes	series	sku	veneer	style	base codes	finish	grommet placement
	<input type="checkbox"/> H itinerary <input type="checkbox"/> C accessories		<b>grade 1</b> <input type="checkbox"/> F plain/abstract laminate <input type="checkbox"/> W woodgrain laminate <b>grade 2</b> <input type="checkbox"/> C oak <input type="checkbox"/> E maple <input type="checkbox"/> J cherry <input type="checkbox"/> 9 walnut <b>grade 3</b> <input type="checkbox"/> Q anigre	<input type="checkbox"/> F flat edge <input type="checkbox"/> X none	<input type="checkbox"/> 8 casters <input type="checkbox"/> 9 glides <input type="checkbox"/> X none	see finish selections	see grommet location codes

### Series Selections

H Itinerary  
The Itinerary collection offers a variety of mobile and stationary training and conferencing tables with options for ganging and grouping in a flexible environment. Available in laminate or veneer options. Itinerary tables are GREENGUARD certified.

C Accessories  
Bernhardt Design offers a variety of accessories including media carts, markerboards, and power management equipment.

### SKU Selections

Sku/Product Number  
A three character sku identifies each product. Information including dimensions, weight and pricing is provided for each sku.

### Veneer Selections

#### Laminates - Grade 1

- F Plain/Abstract Laminates
- W Woodgrain Laminates

A variety of standard laminate finishes are available with vinyl edge bands specifically formulated to correspond to standard laminates. Additional laminate colors or edge bands may be available in combinations not listed as standard but are subject to upcharges and extended lead times. The laminate option is available on components where noted as an option in the series specification code. See finish selections for standard laminates and edge bands.

#### Veneer - Grade 2

- C Oak Rift Cut
- E Maple Flat Cut
- J Cherry Flat Cut

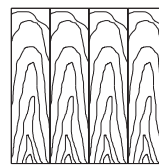
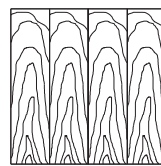
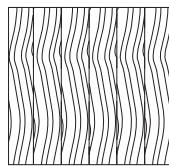

- 9 Walnut Flat Cut
- Q Anigre Quarter Cut

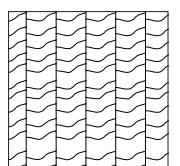
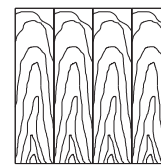

### Style Selections

- F Flat Edge - Wood and Vinyl



### Base Selection

- 8 Casters Non-leveling
- 9 Glides

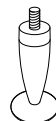
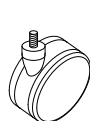

**Folding Tables**

Designed for use in flexible environments requiring reconfigurations and easy storage. Available with a 1 1/4" thick top in wood veneer or a laminate top with vinyl edge band. See veneer and laminate options. Grain will run the length of the table in veneer applications. Tops are pre-machined for ganging brackets and corner top attachment brackets. Communication grommets are available for wire management. Grommet placement must be specified when ordering table. See specification information and grommet location codes. Shipped assembled.

Two base options are available. The mobile base option utilizes four non-levelling 80mm dual wheel casters and two of the casters are locking. The fixed base option has four turned aluminum glides with a polished aluminum finish to match the base.

A 1 1/4" x 8" h modesty panel on the folding training table conceals electrical and power components when extended. When stored, the panel folds allowing the table to nest tightly in storage. Both sides of the modesty panel are finished in the surface material of the top specified. The YEC electrical module has been designed specifically for power management with the folding modesty panel training table. See power module options.

Two options are available for providing power to folding conference tables without a modesty panel. The YEB crossbar electrical module is used with the 9" communication grommet and attaches to the center crossbar in one of three locations on the bar. The E8E power module is self-contained and worksurface mounted. See power module options.

Itinerary folding tables are designed to nest for compact storage. A handle underneath the table top when turned in a clockwise motion, releases the table top to fold. When in the folded position, the tables can be slid together to nest with each table occupying approximately 6" of incremental storage space. See top and side view illustrations.

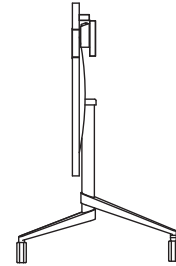
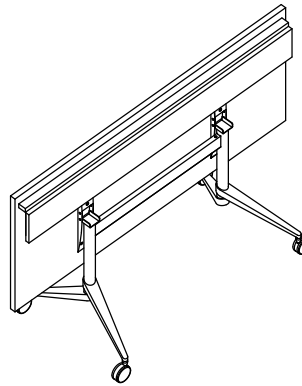

Folding table with modesty panel with 9" grommet and VEC electrical module

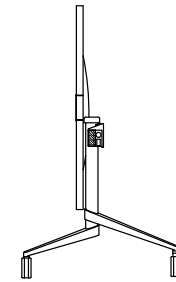
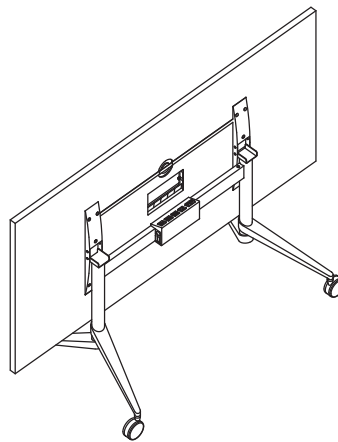

Folding table with center 9" grommet and VEB crossbar electrical module

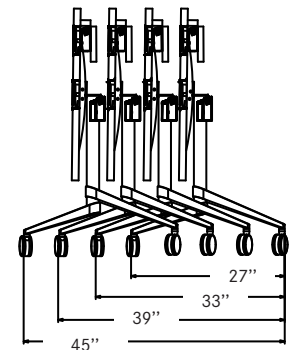
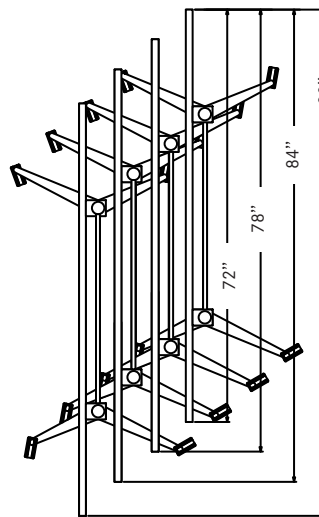

Nesting Configuration: Top view of four tables nested. Approximate dimensions based on 72" table top.

Nesting Configuration: Side view of four tables nested. Approximate dimensions.

### Communication Grommets

The communication grommet is installed into a work surface to allow the passage of wires through the surface to a power or communication source beneath. The units easily open to provide wire passage. Two options of 9" communication grommets are available: an anodized aluminum grommet with brushed aluminum finish, and a cast aluminum grommet with wood veneer or laminate panels that match the finish on the table top. The 9" communication grommet may be used in conjunction with power modules on tables 30"d or larger.

The position along the length of the table must be specified on the purchase order when ordering the top. Grommets cannot be changed or added after an order is acknowledged and entered into production.

**Communication Grommet  
Brushed Aluminum Finish**

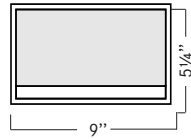

**VFA - Brushed Aluminum Finish**

**Communication Grommet  
Wood Veneer or Laminate Panel**

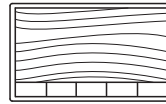

**VFD - Veneer Finish Grain Long**

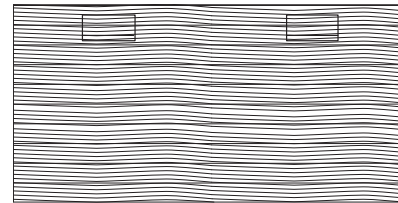

Veneer grain runs the length of the top (long direction).

### Grommet Location Codes

#### Itinerary Tables

**HSA** grommet location  
Use with all top sizes  
Specify E8E module separately



**HSB** grommet location  
Use with all top sizes  
Specify E8E modules separately



**HAB** grommet location  
Use with tops 30" - 40"d  
Specify VFA or VFD grommets separately  
Specify modesty panel  
Specify YEC electrical module



**HAC** grommet location  
Use with tops 30" - 40"d  
Specify VFA or VFD grommets separately  
Specify modesty panel  
Specify YEC electrical module

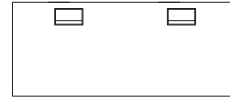

**SAA** grommet location  
Use with tops 30" - 40"d  
Specify VFA or VFD grommets separately



**Power Modules**

The power module is an interconnection device which works in conjunction with the 9” communication grommet and integrates convenient grounded receptacles and communication data modules.

The YEB crossbar electrical module, designed for mounting on the crossbar of the folding conference table 30”d and larger, has four grounded outlets – 120 volt, 60 Hz; 15 amp – with one outlet rotated for transformer plugs, an integrated switch and breaker and a 9’ cord with a three wire grounded plug. Also included: two Amp® RJ45 Cat5e jacks on the top with two RJ45 extension jacks on the side. UL Listed, CSA Approved. Polished chrome faceplate with brushed stainless steel housing box and data modules.

The YEC folding modesty panel electrical module was designed specifically for power management with the folding modesty panel training table 30”d and larger. Includes four rounded outlets – 120 volt, 60 Hz, 15amp – with one outlet rotated for transformer plugs, an integrated switch and breaker; 9’ cord with a three-wire grounded plug. Also included: two Amp® RJ45 Cat5e extension jacks on the top and side. UL Listed, CSA Approved. Brushed stainless steel housing box and data modules with a black mounting plate.

A self-contained, worksurface mounted, power module features two 110 volt outlets with a 6’ cord with a three-wire grounded plug integrated with two Amp® RJ45 Cat5e jacks with 9’ cable and plug. UL Listed, CSA Approved. Matte black plastic. The E8E is the only power module for use on a 27”d table.

**Crossbar Electrical Module**

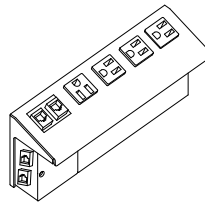

**YEB**  
For use with SAA Grommet Locations

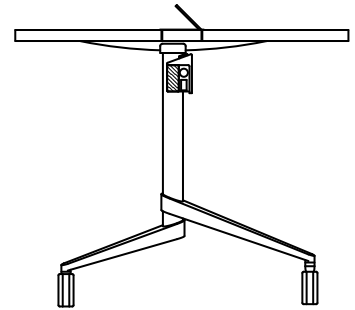

**Folding Modesty Panel Electrical Module**

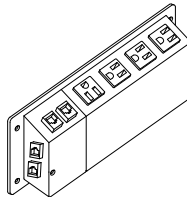

**YEC**  
For use with the HAB and HAC Grommet Locations and a Modesty Panel

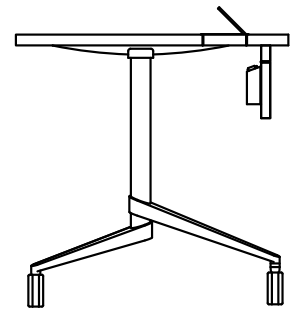

**Worksurface Power Module**

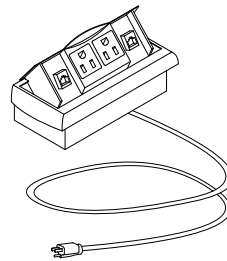

**E8E**

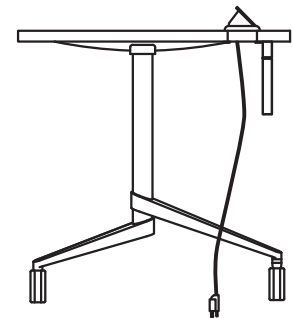

**itinerary tables**



polished aluminum glides or casters  
 shipped assembled  
 approved for GSA Contract GS-28F-7040G  
 GREENGUARD Certified

**folding rectangular training table**

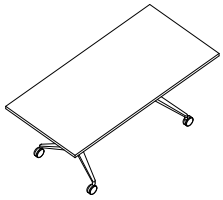

sku	l	w	h	weight	specifications	plain or abstract laminate	woodgrain laminate	cherry maple oak walnut	anigre
Y3L	60	27	29	95	use with E8E power module	\$ 2404	\$ 2524	\$ 2700	\$ 3024
Y3M	66	27	29	100	use with E8E power module	2504	2629	2813	3151
Y3N	72	27	29	105	use with E8E power module	2618	2749	2940	3293
Y3P	78	27	29	110	use with E8E power module	2835	2977	3183	3565
Y3A	60	30	29	105		2404	2524	2700	3024
Y3B	66	30	29	110		2504	2629	2813	3151
Y3C	72	30	29	115		2618	2749	2940	3293
Y3D	78	30	29	120		2835	2977	3183	3565
Y3E	84	30	29	130		2912	3058	3270	3662
Y3F	72	36	29	130		2694	2829	3025	3388
Y3G	78	36	29	140		2912	3058	3270	3662
Y3H	84	36	29	150		3015	3166	3384	3790
Y3J	72	40	29	145		2828	2969	3174	3555
Y3K	78	40	29	155		3020	3171	3390	3797

**folding trapezoid shape training table**

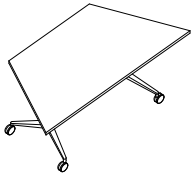

Y4B	60	27	29	90	42" end, use E8E power module	2472	2596	2775	3108
Y4D	72	27	29	95	48" end, use E8E power module	2695	2830	3026	3389
Y4A	60	30	29	100	42" end	2472	2596	2775	3108
Y4C	72	30	29	110	48" end	2695	2830	3026	3389
Y4K	60	36	29	110	42" end	2573	2702	2889	3236
Y4F	72	36	29	125	48" end	2804	2944	3148	3526

**specification codes**

series	sku	veneer	style	pull/hardware	finish	grommet placement
[H] itinerary		<b>grade 1</b> [F] plain/abstract laminate [W] woodgrain laminate <b>grade 2</b> [J] cherry [E] maple [C] oak [Q] walnut <b>grade 3</b> [Q] anigre	[F] flat edge	[8] casters [9] glides	see appendix	
[H]			[F]			

**itinerary tables**



folding modesty panel conceals power management accessories  
 1¼" x 8" h modesty panel  
 polished aluminum glides or casters  
 veneer code is for both top and modesty panel  
 shipped assembled

approved for GSA Contract GS-28F-7040G  
 GREENGUARD Certified

**folding rectangular training table**

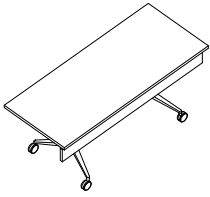

sku	l	w	h	weight	specifications	plain or abstract laminate	woodgrain laminate	cherry maple oak walnut	anigre
Y2A	60	27	29	110	use with E8E power module	\$ 3018	\$ 3169	\$ 3570	\$ 3998
Y2B	66	27	29	115	use with E8E power module	3113	3269	3740	4189
Y2C	72	27	29	125	use with E8E power module	3213	3374	3868	4332
Y2D	78	27	29	130	use with E8E power module	3418	3589	4114	4608
Y2E	60	30	29	115		3018	3169	3629	4064
Y2F	66	30	29	125		3113	3269	3740	4189
Y2G	72	30	29	130		3213	3374	3868	4332
Y2H	78	30	29	140		3418	3589	4114	4608

**specification codes**

**series**

[H] itinerary

[H]

**sku**

\_\_\_\_

**veneer**

- grade 1**
- [F] plain/abstract laminate
- [W] woodgrain laminate
- grade 2**
- [J] cherry
- [E] maple
- [C] oak
- [Q] walnut
- grade 3**
- [Q] anigre

[ ]

**style**

[F] flat edge

[F]

**pull/hardware**

- [8] casters
- [9] glides

[ ]

**finish**

see appendix

\_\_\_\_

**grommet placement**

\_\_\_\_

**itinerary tables**

mounting hardware included  
 approved for GSA Contract GS-28F-7040G  
 GREENGUARD Certified



**quarter round shape  
corner top**

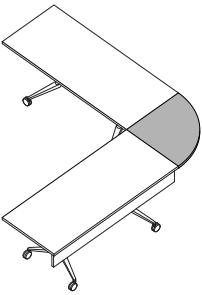

sku	w	d	h	weight	specifications	plain or abstract laminate	woodgrain laminate	cherry maple oak walnut	anigre
YFA	27	27	1¼	30	1¼" thick top	\$ 832	\$ 874	\$ 973	\$ 1090
YFB	30	30	1¼	35	1¼" thick top	918	964	1075	1204
YFC	36	36	1¼	50	1¼" thick top	1009	1059	1182	1324
YFD	40	40	1¼	65	1¼" thick top	1083	1137	1267	1419

specify style code F

**ganging brackets**



E8D	6	2¾	¼	3	42" end, use E8E power module	104	-	-	-
-----	---	----	---	---	-------------------------------	-----	---	---	---

two sets for ganging two tables  
 field installed  
 specify veneer and style code X

**specification codes**

**series**

itinerary

**sku**

**veneer**

- grade 1**
- plain/abstract laminate
- woodgrain laminate
- none
- grade 2**
- cherry
- maple
- oak
- walnut
- grade 3**
- anigre

**style**

- flat edge
- none

**pull/hardware**

- none

**finish**

see appendix

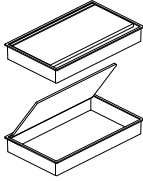
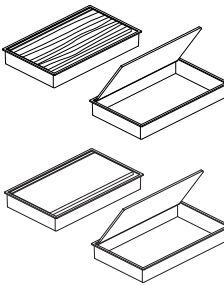
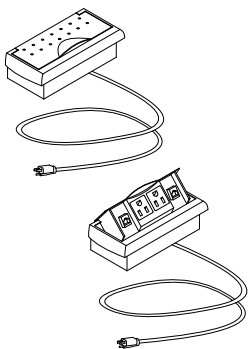
description	sku	w	d	h	weight	specifications	grade 1	grade 2	grade 3
 <p><b>communication grommet aluminum</b></p> <p>anodized aluminum                      use with laminate or veneer tops                      use on top 30" d and larger                      cannot use on 27" d tops                      specify location when ordering top                      specify series code K                      specify veneer code X                      specify pull/hardware code 4                      approved for GSA                      contract GS-28F-7040G</p>	VFA	9	5 1/4	1 1/4	5		\$ 229	-	-
 <p><b>communication grommet wood</b></p> <p>brushed nickel frame                      quarter cut veneer or laminate panel                      use on top 30" d and larger                      cannot use on 27" d tops                      specify location when ordering top                      specify series code W                      specify veneer and finish codes                      specify pull/hardware code 4                      approved for GSA                      contract GS-28F-7040G</p>	VFD	9	5 1/4	1 1/4	5		-	410	410
 <p><b>worksurface power module</b></p> <p>self-contained worksurface mounted                      matte black plastic                      two grounded outlets                      two Cat5e Amp® RJ45 data jacks with 9' cable and plug                      may be used on 27" d tops and larger                      specify series code C                      specify veneer code X                      specify pull/hardware code X                      approved for GSA                      contract GS-28F-7040G</p>	E8E	7	3	1 1/4	5	6' cord with a three-wire grounded plug	625	-	-

specification codes

series

- W wood
- C accessories
- K components

sku

veneer

- grade 1**
- F plain/abstract laminate
- W woodgrain laminate
- X none
- grade 2**
- C oak
- E maple
- J cherry
- 9 walnut
- grade 3**
- Q anigre

style

- X none
- X

base

- 4 anodized/brushed
- X none

finish

grommet

- X none
- X

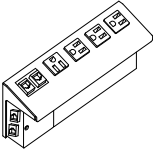
description	sku	w	d	h	weight	specifications	grade 1	grade 2	grade 3
 <p><b>crossbar electrical module</b></p> <p>specify for folding table application with SAA grommet location                      polished chrome faceplate in brushed stainless steel housing                      four grounded outlets with one rotated for transformer plugs                      two Amp® RJ45 Cat5e data jacks on the top                      two Amp® RJ45 Cat5e extension jacks on the side                      approved for GSA                      contract GS-28F-7040G</p>	YEB	9	2¾	4	3	9' cord with a three-wire grounded plug	\$ 530	-	-
 <p><b>folding modesty panel electrical module</b></p> <p>specify for folding modesty panel applications                      with HAB and HAC grommet locations and a modesty panel                      black powdercoat faceplate in brushed stainless steel housing                      four grounded outlets with one rotated for transformer plugs                      two Amp® RJ45 Cat5e extension jacks on the top and side                      approved for GSA                      contract GS-28F-7040G</p>	YEC	9	1½	4	3	9' cord with a three-wire grounded plug	471	-	-
 <p><b>wire clip</b></p> <p>for folding table leg                      snaps around table leg                      clear polycarbonate                      2 per package                      approved for GSA                      contract GS-28F-7040G</p>	YC2	2¾	2½	5/8	1		11	-	-
 <p><b>wire management clip</b></p> <p>for underside of table                      4 clips per package gray finish                      approved for GSA                      contract GS-28F-7040G</p>	E5E	1	1	7/8	1		37	-	-

specification codes	series	sku	veneer	style	pull/hardware	finish	grommet
	<input type="checkbox"/> accessories		<input checked="" type="checkbox"/> none	<input checked="" type="checkbox"/> none	<input checked="" type="checkbox"/> none	none	<input checked="" type="checkbox"/> none
	<input type="checkbox"/>	<input type="checkbox"/>	<input checked="" type="checkbox"/>	<input checked="" type="checkbox"/>	<input checked="" type="checkbox"/>	<input checked="" type="checkbox"/> <input checked="" type="checkbox"/> <input checked="" type="checkbox"/>	<input checked="" type="checkbox"/>

**Finish Selections**

□□□ Finish Number

A three character sku identifies the finish on each species or the laminate/edge band selection available. Individual components are priced with standard finish or standard laminate with edge band.

A variety of standard laminate finishes are available with vinyl edge bands specifically formulated to correspond to standard laminates. Additional laminate colors or edge bands may be available in combinations not listed as standard but are subject to upcharges and extended lead times. The laminate option is available on components where noted as an option in the series specification code. Listed are the standard laminates and edge bands.

Special finishes on veneers made to customer specifications are subject to factory approval and a 20% net upcharge with a \$500 net minimum.

Transparent stains and sealers are applied in multiple steps to enhance the beauty of the natural wood. A durable, baked-on, top-coat of conversion varnish or UV topcoat is applied to protect the product. It is recommended that felt, cork or fabric backed desk pads and accessories are used on worksurfaces to minimize wear.

When specifying light finishes such as 836, 837, 840 or 850, the color and characteristic variances of both veneer and solid wood are apparent. Therefore, exact color matches are not possible.

**Q Anigre**

Standard Finish	
805	840
823	841
834	850
836	860
839	

**J Cherry**

Standard Finish	
805	839
834	840
835	841
836	

**E Maple**

Standard Finish	
837	
850	

**C Oak**

Standard Finish	
805	840
836	860
837	865
839	

**9 Walnut**

Standard Finish	
823	
839	
841	
860	

**F Laminate**

Standard Plain/Abstract

601	Solid White, Nevamar S-7004T, with Solid White Edge
602	Neutral Gray, Nevamar S-6012T, with Platinum Edge
603	Sandpiper, Nevamar S-6047T, with Dove Grey Edge
604	Winter Gray Matrix, Nevamar MR-6005T, with Platinum Edge
605	Straw Matrix, Nevamar MR-2006T, with Platinum Edge
606	Carmen Red, Nevamar S-1049T, with Spectrum Red Edge
607	Gray Matrix, Nevamar MR6001T, with Grey Nebula Edge
611	Designer White, Wilsonart D354-60, with Designer White Edge
612	Frosty White, Wilsonart 1573-60, with Frosty White Edge
613	Putty, Wilsonart 1503-60, with Putty Edge
614	Natural Almond, Wilsonart D30-60, with Almond Edge
615	Antique White, Wilsonart 1572-60, with Antique White Edge
616	Grey, Wilsonart 1500-60, with Grey Edge
617	Featherstone, Wilsonart D72-60, with Featherstone Edge
618	Haze, Wilsonart D97-60, with Haze Edge
620	Khaki Brown, Wilsonart D50-60, with Khaki Brown Edge
621	Pepperdust, Wilsonart D327-60, with Pepperdust Edge
622	Platinum, Wilsonart D315-60, with Platinum Edge
623	Fashion Grey, Wilsonart D381-60, with Fashion Grey Edge
624	Dove Grey, Wilsonart D92-60, with Dove Grey Edge
628	Amazon, Wilsonart D478-60, with Amazon Edge
630	Hunter Green, Wilsonart D79-60, with Hunter Green Edge
632	Slate Grey, Wilsonart D91-60, with Slate Grey Edge
633	Black, Wilsonart 1595-60, with Black Edge
634	North Sea, Wilsonart D90-60, with North Sea Edge
640	Natural Nebula, Wilsonart 4633-60, with Wallaby Edge
641	Neutral Glace Nebula, Wilsonart 4143-60, with Beige Edge
642	Graphite Nebula, Wilsonart 4623-60, with Black Edge
643	White Nebula, Wilsonart 4621-60, with Platinum Edge

**W Woodgrain Laminate**

Standard Woodgrain

650	Fusion Maple, Wilsonart 7909-60, with Natural Maple Edge
651	Solar Oak, Wilsonart 7816-60, with Solar Oak Edge
654	Colombian Walnut, Wilsonart 7943-07, with Colombian Walnut Edge
655	Shaker Cherry, Wilsonart 7935-07, with Cherry Blossom Edge
656	Versailles Anigre, Wilsonart 7923K-07, with Versailles Anigre Edge
657	Brighton Walnut, Wilsonart 7922K-07, with Brighton Walnut Edge
658	New Age Oak, Wilsonart 7938-38, with Clear Maple Edge
670	Gunstock Savoy Walnut, Pionite WW971, with Columbian Walnut Edge
675	Blossom Cherrywood, Formica 758-58, with Oiled Cherry Edge
676	Lacewood, Formica 744-58, with Lacewood Edge
685	Grand Isle Maple, Nevamar W8371T, with African Limba Edge
686	Valencia Teak, Nevamar WT0003PV, with Shadow Oak Edge
687	Sovereign Cherry, Nevamar W8325T, with Wild Cherry Edge

**Grommet Placement Selections**

Communication grommets are available in worksurfaces for wire management. The exact placement of the grommet must be specified on the purchase order and cannot be changed or added after an order is acknowledged and entered into production. See grommet specification information and location codes.

**not be replaced because of these natural characteristics.****Special Finishes**

Special finishes, made to customer specifications and subject to factory approval, may be available at a **20% net upcharge with a \$500 net minimum**. Additional leadtime may be required for special finish items. Special finish orders will not be acknowledged until the special finish sample is approved in writing and received by Bernhardt Design Customer Service. Special finish orders are not subject to revision or cancellation after acknowledgment.

**Warranty**

Bernhardt Design will repair or replace, at its discretion and without charge to the original purchaser, any table product or part thereof which fails as the result of defects in material and workmanship, under single shift use and normal care, for five years from date of shipment.

This warranty does not cover misuse or abuse of product, dramatic temperature changes, exposure to unusual conditions, or damages incurred by contact with seating products.

Repair or replacement of discontinued product will be at the discretion of Bernhardt Design.

Natural color changes, variations or movements in lumber or veneer products, exposure to extreme temperature changes and direct sunlight may cause color changes and/or surface damage. These are circumstances beyond the control of Bernhardt Design and are not warranty issues.

Drawer glides, drawer boxes, drawer pulls, and locking mechanisms have a Life-Time Warranty for the original purchaser. Power or communications components are warranted for one (1) year.

This warranty is the customer's exclusive remedy for product defect and does not apply to damage caused by a carrier, dealer, installer, user modification, or attachments to a product.

Bernhardt Design has the exclusive right to make the final determination of product misuse or abuse. Except as stated above, Bernhardt Design makes no express or implied warranties as to any product, and in particular, makes no warranty of merchantability or of fitness for any particular purpose.

Bernhardt Design shall not be liable for any consequential or incidental damages or for commercial loss arising from any product defect. The Bernhardt Design customer is the dealer. All complaints must be resolved through the dealer from which the furniture was purchased. To obtain warranty service the dealer must supply dated proof of purchase. This warranty gives you specific legal rights. You may also have other rights which vary from state to state.

Some states do not allow limitations on how long an implied warranty will last or the exclusion or limitation of incidental or consequential damages, so the above limitations or exclusions may not apply.

**Design and Patent Rights** All of the products shown in Bernhardt Design catalogs and described in Bernhardt Design price lists are, and remain, the property of Bernhardt Design, with the sole right reserved to manufacture and to distribute.

Some of the product designs shown are patented in the United States and will remain the property of Bernhardt Design. Any reproduction of the products constitutes an infringement of patented copyright laws and will be subject to prosecution.

Bernhardt Design reserves the right to make changes in dimensions, design and/or construction, price lists, or product literature without prior notice.

**General Services Administration**

Products available on the Bernhardt Design GSA - Federal Supply Service Contract GS-28F-7040G are noted in the product descriptions.

For information regarding GSA pricing, please contact your local Bernhardt Design sales representative or call 828 759 6337.

Send all GSA payments to:  
12197 Collections Center Drive  
Chicago IL 60693

**Prices and Terms**

Prices and specifications are subject to change without notice. All prices quoted will be FOB our factories. Terms are net 30 days. A service charge of 1½% per month will be charged on all past due accounts.

**Order Entry**

All orders are subject to final acceptance by Bernhardt Design in Lenoir, NC. Receipt of our acknowledgment indicates acceptance of your order subject to the terms set forth on the acknowledgment.

Bernhardt Design attempts to clarify all purchase orders. However, in the event the price list number and description on the purchase order differ, the price list number will prevail.

**Change Orders**

All reasonable requests for changes to standard table orders will be honored if received in writing prior to the start of production. Custom design and special finish orders are not subject to revision after acknowledgment. Bernhardt Design reserves the right to charge for labor, materials and administration costs for all order changes.

**Cancellations**

All acknowledged orders are considered as firm orders and are not subject to cancellation.

**Custom Design**

Bernhardt Design may alter products to meet specific needs. Contact your local sales representative when a custom design is needed. Custom designs require minimum quantities, additional lead time and upcharges. A custom job number, available from your local sales representative, must be submitted with purchase orders. Orders combining custom design with standard product cannot be scheduled for production until custom items are approved.

**Shipping**

Bernhardt Design will ship in accordance with customer instructions whenever possible. If not specified, Bernhardt Design will exercise its best judgement in selecting a carrier. Orders in production will be shipped as scheduled and cannot be held.

High quality cartoning which meets trucking and railroad specifications is standard at no extra charge.

**Storage**

If a customer is unable to accept an order when it is ready for shipment, storage may be requested. Acceptance of storage will be at the discretion of Bernhardt Design. All costs including transportation will be at customer expense. A storage charge of 1½% of the invoice will be assessed for every 30 days, or any part thereof, that merchandise remains in storage.

Bernhardt Design considers transfer to storage the equivalent of delivery. This includes invoicing and payment. Customers will bear all risk of damage or loss during storage.

**Freight Damage and Claims**

Bernhardt Design is not liable for damages that occur during transit or storage. The carrier assumes all responsibility upon acceptance of product. It is the customer's responsibility to inspect all products upon receipt and file any claims with the carrier. No product should be refused. If products are received damaged, a written exception should be made on the bill of lading and an immediate inspection be requested of the carrier. Concealed damage must be reported to the carrier within 15 days of receipt. Failure to make claims shall constitute acceptance of the products and waiver any claims of defects, errors or shortages.

In the event delivery is made on a Bernhardt Design truck, the products should be carefully inspected for transit damage. If contents are damaged, the driver should be notified to call his dispatcher for immediate disposition. Concealed damage must be reported within 15 days of receipt and product/ packaging held for inspection by a Bernhardt Design representative. Replacements for product damaged in shipment or storage will be manufactured upon receipt of a purchase order.

**Returns**

No merchandise may be returned to Bernhardt Design without written consent in the form of a Return Authorization from our Quality Assurance Department stating

why the item is being returned and how the item will be shipped.

In the event a return is authorized by Bernhardt Design for reasons other than damage or defect, the customer shall be responsible for a 25% restocking fee, as well as a double freight charge.

Unauthorized returns will be automatically refused by our receiving department as well as returns not in accordance with Bernhardt Design shipping instructions. Liability for defective merchandise shall be limited to the replacement or repair of that merchandise, and Bernhardt Design shall not be liable for other damages or losses.

**Measurements and Weights**

All measurements and weights are approximate and subject to change without notice.

**Care and Cleaning**

Finished wood surfaces should be cleaned with a soft damp cloth, wiping in the direction of the grain. Dry with a soft cloth, wiping in the grain direction. Do not use waxes or furniture polish, as these will cause a film build-up.

**Wood Finishes**

Bernhardt Design tables are available in standard finishes compatible with casegoods and seating finishes. However, finishes on tables may vary slightly from those on casegoods and seating due to the natural characteristics of the wood. No absolute match is implied or guaranteed.

**Light Finishes**

**Bernhardt Design offers lighter finishes 836, 837, 840, and 850. Light finishes do not hide or mask the natural characteristics of the wood. It is important that the dealer and customer understand that inherent natural characteristics of the wood will vary from piece to piece when using a light finish. Natural characteristics include the natural discolorations of the wood substance and color variations in glued up stock.**

**These natural characteristics are not considered defects by Bernhardt Design, and therefore merchandise will**

**not be replaced because of these natural characteristics.****Special Finishes**

Special finishes, made to customer specifications and subject to factory approval, may be available at a **5% net upcharge with a \$500 net minimum**. Additional leadtime may be required for special finish items. Special finish orders will not be acknowledged until the special finish sample is approved in writing and received by Bernhardt Design Customer Service. Special finish orders are not subject to revision or cancellation after acknowledgment.

**Warranty**

Bernhardt Design will repair or replace, at its discretion and without charge to the original purchaser, any table product or part thereof which fails as the result of defects in material and workmanship, under single shift use and normal care, for five years from date of shipment.

This warranty does not cover misuse or abuse of product, dramatic temperature changes, exposure to unusual conditions, or damages incurred by contact with seating products.

Repair or replacement of discontinued product will be at the discretion of Bernhardt Design.

Natural color changes, variations or movements in lumber or veneer products, exposure to extreme temperature changes and direct sunlight may cause color changes and/or surface damage. These are circumstances beyond the control of Bernhardt Design and are not warranty issues.

Drawer glides, drawer boxes, drawer pulls, and locking mechanisms have a Life-Time Warranty for the original purchaser. Power or communications components are warranted for one (1) year.

This warranty is the customer's exclusive remedy for product defect and does not apply to damage caused by a carrier, dealer, installer, user modification, or attachments to a product.

Bernhardt Design has the exclusive right to make the final determination of product misuse or abuse. Except as stated above, Bernhardt Design makes no express or implied warranties as to any product, and in particular, makes no warranty of merchantability or of fitness for any particular purpose.

Bernhardt Design shall not be liable for any consequential or incidental damages or for commercial loss arising from any product defect. The Bernhardt Design customer is the dealer. All complaints must be resolved through the dealer from which the furniture was purchased. To obtain warranty service the dealer must supply dated proof of purchase. This warranty gives you specific legal rights. You may also have other rights which vary from state to state.

Some states do not allow limitations on how long an implied warranty will last or the exclusion or limitation of incidental or consequential damages, so the above limitations or exclusions may not apply.

**Design and Patent Rights** All of the products shown in Bernhardt Design catalogs and described in Bernhardt Design price lists are, and remain, the property of Bernhardt Design, with the sole right reserved to manufacture and to distribute.

Some of the product designs shown are patented in the United States and will remain the property of Bernhardt Design. Any reproduction of the products constitutes an infringement of patented copyright laws and will be subject to prosecution.

Bernhardt Design reserves the right to make changes in dimensions, design and/or construction, price lists, or product literature without prior notice.

**General Services Administration**

Products available on the Bernhardt Design GSA - Federal Supply Service Contract GS-28F-7040G are noted in the product descriptions.

For information regarding GSA pricing, please contact your local Bernhardt Design sales representative or call 828 759 6337.

Send all GSA payments to:  
12197 Collections Center Drive  
Chicago IL 60693